

# General Specifications

## ZR22S, ZR802S, and ZR202S Explosion-proof Zirconia Oxygen Analyzers

GS 11M13G01-01EN

### Overview

Two types are available explosion-proof direct insertion zirconia oxygen analyzer.

The separate type which consists ZR22S of explosionproof detector and ZR802S of explosionproof converter.

The integrated type ZR202S combining explosionproof detector and converter.

Separate and integrated type Zirconia oxygen analyzers do not need a sampling device, and allow direct installation of the probe in the wall of a flue or furnace to measure the concentration of oxygen in the stack gas.

The ZR802S converter uses a digital display, displays the cell temperature and cell emf in addition to the oxygen concentration and includes a Human Machine Interface (HMI), that offers easy touch screen operation.

This analyzer is most suitable for monitoring combustion and controlling the low-oxygen combustion of various industrial furnaces in explosive atmosphere at petroleum refinery, petrochemical plant, and natural gas plant.



### Features:

- The built-in heater assembly of the probe can be replaced on site, reducing maintenance costs.
- The probe uses a long-life, high-reliability Zirconia sensor.
- The probe uses three-reference gas supply methods (natural air convection, instrument air, and pressure compensated) in its applications.
- The converter incorporates the LCD touchscreen for ease of operation.
- The deterioration status of the sensor can be confirmed by the sensor resistance check function (self-diagnosis function) in the converter.
- The converter records history of alarm on/off, measured value history for up to 41 days, and others.
- The integrated type integrates both probe and converter, to reduce wiring, piping, and installation costs. This type of unit uses an optical switch for ease of operation at the site.
- Remote maintenance using digital communications (HART, Modbus RTU) reduces maintenance costs. \*1

\*1: HART is a registered trademark of HART Communication Foundation

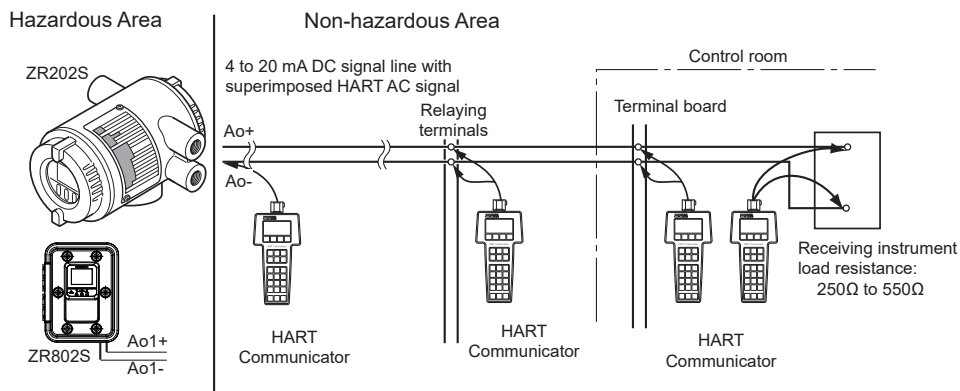

All other company and product names mentioned in this document are trademarks or registered trademarks of their respective companies.

Please select appropriate equipment in accordance with the laws and regulations of the relevant country/region, when it is used in a location where explosive atmospheres may be present.

## Basic System Configuration

### System configuration – Separate type Explosion-proof (Automatic Calibration)

#### System configuration Example 1 of Separate type Analyzer

- Automatic calibration system uses instrument air for reference gas.  
For the calibration gas, a standard gas cylinder may be used for more accurate calibration.
- Applications: Oxygen concentration monitoring and control in boilers.  
(for private and public power generation ) and in heating furnaces.

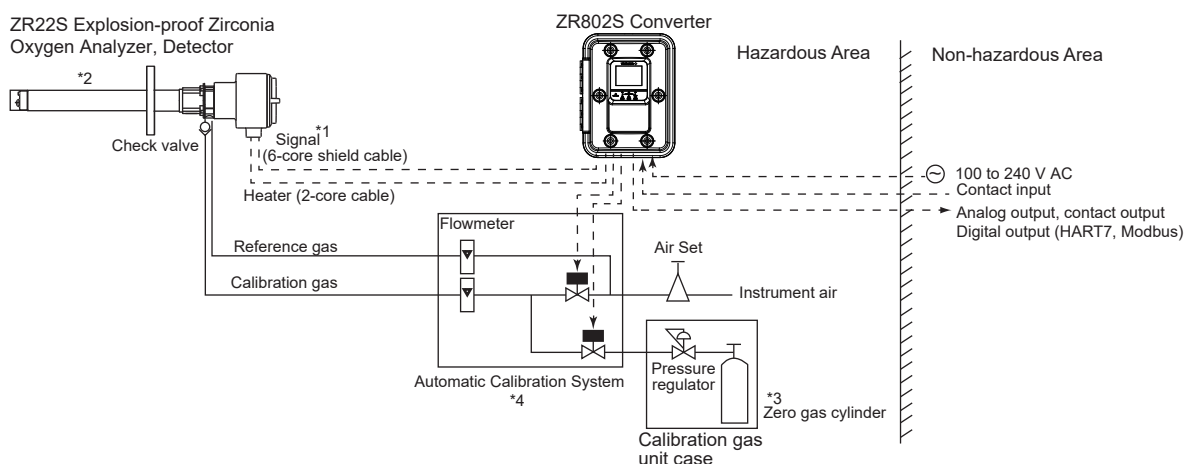

### System configuration – Separate type Explosion-proof (Automatic Calibration) when replacing ZR402G with ZR802G

For ZR802G/ZR40H, refer to GS 11M12G01-01EN.

#### System configuration Example 1 of Separate type Analyzer

- Automatic calibration system uses instrument air for reference gas.  
For the calibration gas, a standard gas cylinder may be used for more accurate calibration.
- Applications: Oxygen concentration monitoring and control in boilers.  
(for private and public power generation ) and in heating furnaces.

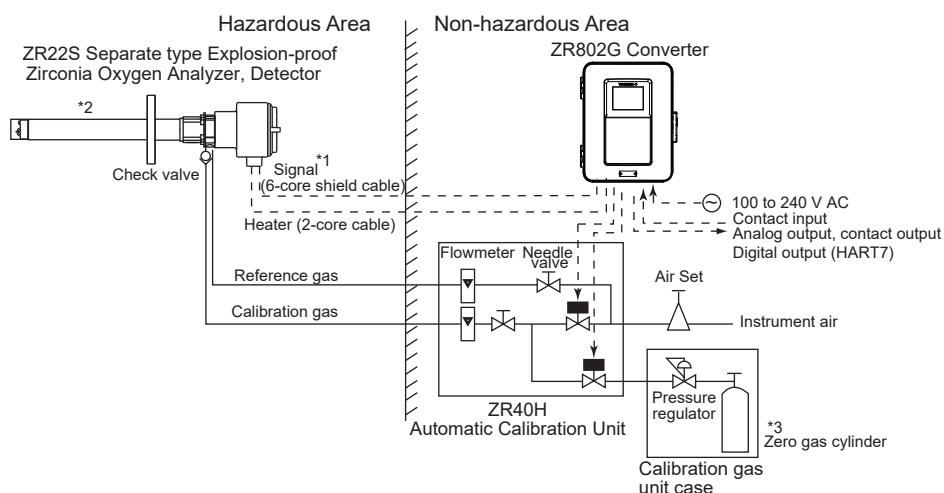

- \*1 Shield cable: Use shielded signal cables, and connect the shields to the FG terminal of the converter.
- \*2 Select the desired probe from the Detector Components table on page 5.
- \*3 When a zirconia oxygen analyzer is used, 100% N<sub>2</sub> gas cannot be used as the zero gas.  
Use approx. 1 vol% O<sub>2</sub> gas (N<sub>2</sub>-balanced).
- \*4 When the option code "/AC" is specified, a solenoid valve drive output will be included. Automatic calibration system should be constructed by customer.

## System configuration – Integrated type Explosion-proof (Automatic Calibration)

### System configuration Example 1 of Integrated type Analyzer

- Automatic calibration system uses instrument air for reference gas.  
For the calibration gas, a standard gas cylinder may be used for more accurate calibration.
- Applications: Oxygen concentration monitoring and control in boilers.  
(for private and public power generation)

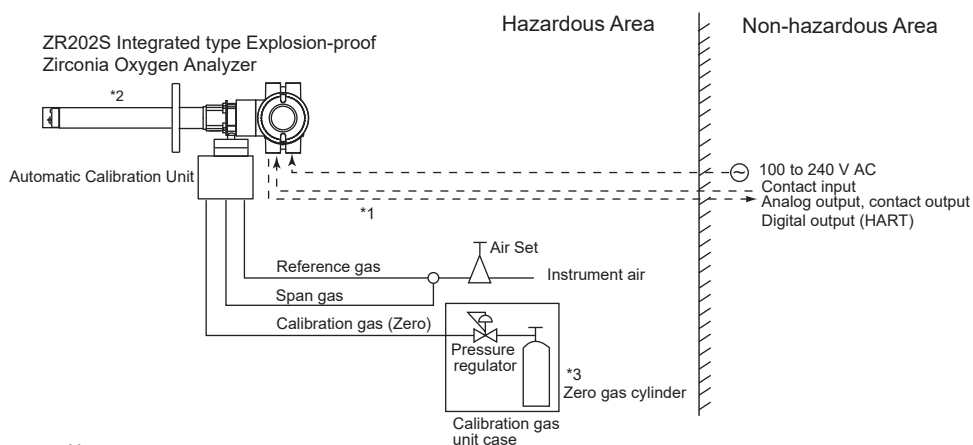

Note:

The installation temperature limits range for integrated type analyzer is -20 to 55 °C.

## System configuration – Separate type Explosion-proof (Manual Calibration)

### System configuration Example 2 of Separate type Analyzer

- Instrument air is used as the reference gas.  
A standard gas cylinder can be used for the calibration gas for more accurate calibration.
- Application example: Oxygen concentration monitoring and control in boilers.  
(for private and public power generation) and in heating furnaces.

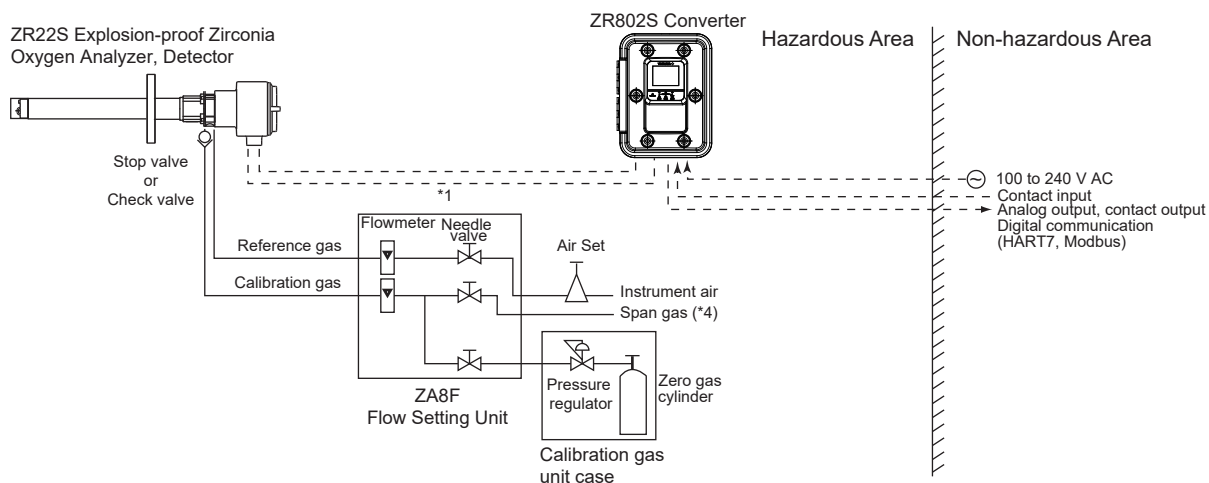

\*1 Shield cable: Use shielded signal cables, and connect the shields to the FG terminal of the converter.

\*2 Select the desired probe from the Detector Components table on page 5.

\*3 When a zirconia oxygen analyzer is used, 100% N<sub>2</sub> gas cannot be used as the zero gas.  
Use approx. 1 vol% O<sub>2</sub> gas (N<sub>2</sub>-balanced).

\*4 Calibration gas unit same as for zero gas.



## System Components

	Model or Part number	System Components	Separate type system config.		Integrated type system config.		When replacing ZR402G with ZR802G	
			Ex.1	Ex.2	Ex.1	Ex.2	Ex.1	Ex.2
1	ZR22S	Explosion-proof Zirconia Oxygen Analyzer, Detector	●	●			●	●
2	ZR802S	Explosion-proof Zirconia Oxygen Analyzer, Converter	●	●				
3	ZR202S	Integrated type Explosion-proof Zirconia Oxygen Analyzer			●	●		
4	ZO21P	Probe Adapter for ZR22S	○	○			○	○
5	E7046EC/E7046EN	Ejector Assembly for High Temperature Probe of Oxygen Analyzer	○	○			○	○
6	ZO21R	Probe Protector for Zirconia Oxygen Analyzer	○	○	○	○	○	○
7	ZA8F	Flow Setting Unit for manual calibration (Needs instrument air.)		●		●		●
8	L9852CB/G7016XH	Stop Valve for Calibration gas line (*1)		(●)		(●)		(●)
9	K9292DN/K9292DS	Check Valve for Calibration gas line (*1)	●	(●)		(●)	●	(●)
10	G7003XF/K9473XK, G7004XF/K9473XG	Air Set	●	●	●	●	●	●
11	G7013XF/G7014XF	Pressure Regulator for Gas Cylinder	●	●	●	●	●	●
12	ZR22A, ZR202A	Heater Assembly	○	○	○	○	○	○
13	E7044KF	Calibration Gas Unit Case	●	●	●	●	●	●
-	ZR802G	Zirconia Oxygen/Humidity Analyzer, Converter					●	●
-	ZR40H	Automatic Calibration Unit for Separate type Analyzer					●	

●: Items required for the above system example

○: To be selected depending on each application. For details, refer to Chapter of Options.

(●): Select either

(\*1): When ZR22S or ZR202S specifies Stop valve (/SV) or Check valve (/CV) as an option code, they are correspondingly installed in the equipment.

## Detector Components

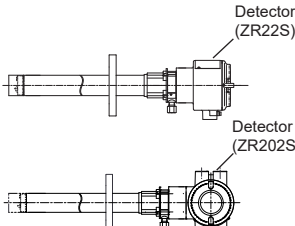
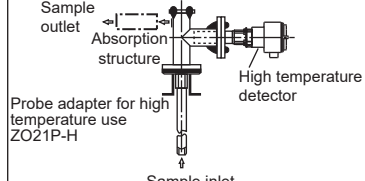
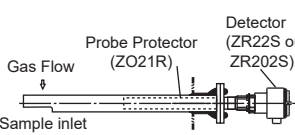
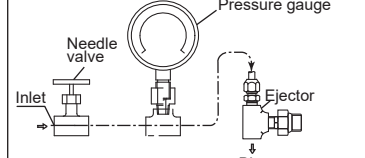
Sample gas temperature 0 to 700°C				Sample gas temperature 700 to 1400°C	
Mounting	Insertion length	General use Probe	Application	High temperature detector	Application
Horizontal to vertical	2 m or less	 <p>Detector (ZR22S) Detector (ZR202S)</p>	Boiler Heating furnace	 <p>Sample outlet Absorption structure High temperature detector Sample inlet</p>	Heating furnace
		 <p>Gas Flow Sample inlet Probe Protector (ZO21R) Detector (ZR22S or ZR202S)</p>	For pulverized coal boiler with gas flow velocity 10 m/sec or more	<p>Temperature: Probe material; SUS310S 800°C Probe material; SiC 1400°C Mounting: Vertical downwards Insertion length: 1.0m, 1.5m When duct pressure is atmospheric or negative, attach air ejector.</p> <p>High temperature ejector assembly (E7046EC, E7046EN)</p>  <p>Inlet Needle valve Pressure gauge Ejector Blow</p>	

## ■ STANDARD SPECIFICATIONS

### Example of Application

Separate and integrated type Zirconia Oxygen Analyzers

- Large, medium and small boilers (boilers for power generation: heavy oil, gas or coal)
- Various industrial furnaces (refinery process/iron manufacture heating furnace, coal kiln, and black liquid recovery boilers) For other applications, contact Yokogawa Electric Corporation.
- May not be applicable corrosive gas such as ammonia, chlorine is present-check with YOKOGAWA.

### General Specifications

Measurement Object: Oxygen concentration in combustion exhaust gas and mixed gas (excluding inflammable gases)

Measurement System: Zirconia system

Oxygen Concentration: 0.01 to 21 vol%O<sub>2</sub>

Note: In the case of explosion-proof use, oxygen concentration shall not exceed that found in normal air, typically 21%

Measurement Range: 0.01 to 100 vol%O<sub>2</sub>

Output Signal: 4 to 20 mA DC (maximum load resistance 550 Ω)

Setting Range:

Any setting in the range of 0 to 5 through 0 to 100 vol%O<sub>2</sub> (in 1 vol%O<sub>2</sub>), or partial range

Display Range: 0 to 100 vol%O<sub>2</sub>

Warming-up Time: Approx. 20 min.

Repeatability:

(Excluding the case where the reference gas is by natural convection) ±0.5% F.S. ; range from 0 to 5 vol% O<sub>2</sub> or more and less than 0 to 25 vol% O<sub>2</sub> range ±1% F.S. ; range from 0 to 25 vol% O<sub>2</sub> or more and up to 0 to 100 vol% O<sub>2</sub> range

Linearity: (Excluding standard gas tolerance and the case where the reference gas is by natural convection) (Use oxygen of known concentration (with in the measuring range) as the zero and span calibration gases.)

± 1% F.S.; 0 to 5 or more and less than 0 to 25 vol% O<sub>2</sub> range and sample gas pressure within ± 4.9 kPa  
± 3% F.S.; 0 to 25 or more and less than 0 to 50 vol% O<sub>2</sub> range and sample gas pressure within ± 0.49 kPa  
± 5% F.S.; 0 to 50 or more and up to 0 to 100 vol% O<sub>2</sub> range and sample gas pressure within ± 0.49 kPa

Drift: (Excluding the first two weeks in use and the case where the reference gas is by natural convection.)

Both zero and span ± 2% F.S. /month

Response Time:

Response of 90% within 5 seconds. (Measured after gas is introduced from calibration gas inlet and analog output starts changing.)

Safety, EMC, and RoHS conformity standards of ZR22S, ZR802S and ZR202S

Installation altitude: 2000 m or less  
Installation category: (IEC61010); II  
Pollution degree: (IEC61010); 2  
Measurement category: O (other)

- Note
- Installation category, called overvoltage category, specifies impulse withstanding voltage. Category II is for electrical equipment.
  - Pollution degree indicates the degree of existence of solid, liquid, gas or other inclusions which reduce dielectric strength. Degree 2 is the normal indoor environment.

Safety :

ZR202S/ZR22S;

CE EN 61010-1  
UL UL61010-1  
CSA CAN/CSA-C22.2 No. 61010-1  
GB GB30439 Part 1  
EAC GOCT 12.2.007.0-75

ZR802S;

CE EN 61010-1  
EN IEC 61010-2-030  
UL UL61010-1  
UL61010-2-030  
CSA CAN/CSA-C22.2 No. 61010-1  
CAN/CSA-C22.2 No. 61010-2-030

Morocco/LVD Arrêté:

NM EN 61010 1  
NM EN 61010 2 030

GB GB30439 Part 1  
EAC GOCT 12.2.007.0-75

EMC:

ZR202S/ZR22S;

CE EN 61326-1 Class A Table 2  
EN 61326-2-3  
EN 61000-3-2, EN IEC 61000-3-2

RCM EN 61326-1 Class A Table 2  
KC Korea Electromagnetic Conformity Standard

한국 전자파적합성 기준

EAC GOCT 30804.6.2  
(IEC 61000-6-2)  
GOCT IEC 61000-6-4

ZR802S;

CE EN 61326-1 Class A Table 2  
EN 61326-2-3,  
EN 61000-3-2, EN IEC 61000-3-2

Morocco/EMC Arrêté:

NM EN 61326 1 Class A Table 2  
NM EN 61326 2 3  
NM EN 61000 3 2

RCM EN61326-1 Class A Table 2  
KC Korea Electromagnetic Conformity Standard

한국 전자파적합성 기준

EAC GOCT 30804.6.2  
(IEC 61000-6-2)  
GOCT IEC 61000-6-4

- Note
- This instrument is a Class A product, and it is designed for use in the industrial environment. Please use this instrument in the industrial environment only.
  - Influence of immunity environment (Criteria A) : Output shift is specified within ±20% of F.S.

RoHS: EN IEC 63000

Others:

REACH Regulation EC 1907/2006  
Information of the WEEE Directive

This product is purposely designed to be used in a large scale fixed installations only and, therefore, is out of scope of the WEEE Directive. The WEEE Directive is only valid in the EU.

## Explosion-proof Approval

Explosion-proof approval of major standards and directives	Detector (ZR22S)	Integrated type (ZR202S)	Converter (ZR802S)
<b>ATEX:</b>			
Applicable Standard:	EN IEC 60079-0 EN 60079-1 EN 60079-31		EN IEC 60079-0 EN 60079-1 EN 60079-31 EN 60529 +A1 +A2
Type of protection	⊕ II 2 G Ex db IIB+H <sub>2</sub> T4...T2 Gb and II 2 D Ex tb IIIC T300°C Db	⊕ II 2 G Ex db IIB+H <sub>2</sub> T2 Gb and II 2 D Ex tb IIIC T300°C Db	⊕ II 2G Ex db IIC T6 Gb ⊕ II 2D Ex tb IIIC T85°C Db
Temperature class for Ex "db"	T4...T2	T2	T6
The maximum surface temperature for Ex "tb"	T300°C	T300°C	T85°C
Ambient temperature	-20°C to 60°C	-20°C to 55°C	-20°C to 55°C
Surface temperature	See page 9 Surface temperature of ZR22S (ATEX, IECEx, GB EX)	See page 9 Surface temperature of ZR202S (ATEX, IECEx)	
Enclosure Rating	IP66		IP66
<b>IECEX:</b>			
Applicable Standard:	IEC 60079-0 IEC 60079-1 IEC 60079-31		IEC 60079-0 IEC 60079-1 IEC 60079-31
Type of protection:	Ex db IIB+H <sub>2</sub> T4...T2 Gb and Ex tb IIIC T300°C Db	Ex db IIB+H <sub>2</sub> T2 Gb and Ex tb IIIC T300°C Db	Ex db IIC T6 Gb Ex tb IIIC 85°C Db
Temperature class for Ex "db"	T4...T2	T2	T6
The maximum surface temperature for Ex "tb":	T300°C		T85°C
Ambient temperature	-20°C to 60°C	-20°C to 55°C	-20°C to 55°C
Surface temperature	See page 9 Surface temperature of ZR22S (ATEX, IECEx, GB EX)	See page 9 Surface temperature of ZR202S (ATEX, IECEx)	
Enclosure Rating	IP66		IP66
<b>FM [Division system]:</b>			
Applicable Standard	FM Class 3600 FM Class 3615  FM Class 3810 ANSI/NEMA 250		FM Class 3600 FM Class 3615 FM Class 3616 FM Class 3810 NEMA 250
Type of protection	Class I, Division 1, Groups B, C and D  Class II/III, Division 1, Groups E, F and G		Class I Division 1, Groups B, C, D; T6  Class II, Division 1, Groups E, F, G, Class III, Division 1; T6
Temperature Class:	T2		T6
Ambient temperature	-20°C to 60°C	-20°C to 55°C	-20°C to 55°C
Enclosure Rating	Type 4X		Type4X, IP66

Explosion-proof approval of major standards and directives	Detector (ZR22S)	Integrated type (ZR202S)	Converter (ZR802S)
<b>FM [Zone system]:</b>			
Applicable Standard	Not applied		ANSI/UL 60079-0 ANSI/UL 60079-1 ANSI/UL 60079-31 ANSI/UL 61010-1 ANSI/UL 61010-2-30 ANSI/UL 50E NEMA 250 ANSI/IEC 60529
Type of protection:			Class I, Zone 1, AEx db IIC T6 Gb Zone 21 AEx tb IIIC T85°C Db
Temperature class for Ex "db"			T6
The maximum surface temperature for Ex "tb":			T85°C
Ambient temperature			-20°C to 55°C
Enclosure Rating			Type4X, IP66
<b>CSA [Division system]:</b>			
Applicable Standard:	C22.2 No.0 C22.2 No. 0.4-04 C22.2 No.0.5 C22.2 No.25 C22.2 No.30 C22.2 No.94 C22.2-No.61010-1-04		Not applied
Type of protection	Class I, Division 1, Groups B, C and D Class II/III, Division 1, Groups E, F and G		
Temperature Class:	T2		
Ambient temperature	-20°C to 60°C		
Enclosure Rating	Type 4X		
<b>CSA [Zone system]:</b>			
Applicable Standard:	Not applied		CSA-C22.2 No. 94.2 CSA-C22.2 No. 60079-0 CAN/CSA-C22.2 No. 60079-1 CAN/CSA C22.2 No.60079-31 CAN/CSA-C22.2 No. 60529 CAN/CSA-C22.2 No. 61010-1 CAN/CSA-C22.2 No. 61010-2-030
Type of protection			Ex db IIC T6 Gb Ex tb IIIC T85°C Db
Temperature class for Ex "db"			T6
The maximum surface temperature for Ex "tb":			T85°C
Ambient temperature			-20°C to 55°C
Enclosure Rating			Type 4X, IP66
<b>EAC:</b>			
Applicable Standard:	ГОСТ 31610.0 ГОСТ IEC 60079-1 ГОСТ IEC 60079-31		ГОСТ 31610.0 ГОСТ IEC 60079-1 ГОСТ IEC 60079-31
Type of protection:	1Ex db IIB+H <sub>2</sub> T2 Gb X Ex tb IIIC T300 °C Db X		1Ex db IIC T6 Gb X Ex tb IIIC T85°C Db X
Temperature class for Ex "db"	T2		T6
The maximum surface temperature for Ex "tb":	T300°C		T85°C
Ambient temperature	-20°C to 60°C	-20°C to 55°C	-20°C to 55°C
Enclosure Rating	IP66		IP66

Explosion-proof approval and registration in specific countries	Detector (ZR22S)	Integrated type (ZR202S)	Converter (ZR802S)
<b>KOREA:</b>			
Applicable Standard:	Notice of Ministry of Labor No. 2016-54		Notice of Ministry of Labor No. 2021-22
Type of protection:	Ex d IIB+H <sub>2</sub> T2 Not applied for "tb"		Ex db IIC T6 Gb Ex tb IIIC 85°C Db
Temperature class for Ex "db"	T2		T6
The maximum surface temperature for Ex "tb":	Not applied		T85°C
Ambient temperature	-20°C to 60°C	-20°C to 55°C	-20°C to 55°C
Enclosure Rating	IP66		IP66
<b>GB EX (CHINA EX):</b>			
Applicable Standard:	GB/T 3836.1	Not applied	GB/T 3836.1
	GB/T 3836.2		GB/T 3836.2
	GB/T 3836.31		GB/T 3836.31
Type of protection:	Ex db IIB + H <sub>2</sub> T2...T4 Gb, Ex tb IIIC T300°C Db		Ex db IIC T6 Gb Ex tb IIIC 85°C Db
Temperature class for Ex "db"	T2...T4		T6
The maximum surface temperature for Ex "tb":	T300°C		T85°C
Ambient temperature	-20°C to 60°C		-20°C to 55°C
Surface Temperature	See page 9 Surface temperature of ZR22S (ATEX, IECEx, GB EX)		
Enclosure Rating	IP66		IP66
<b>TAIWAN EX:</b>			
Registration	IECEx registered and approved for use in Taiwan. For explosion-proof specifications, please refer to the IECEx section.		
<b>INDIA EX:</b>			
Approval	Not applied	IECEx approved for use in INDIA. For explosion-proof specifications, please refer to the IECEx section. However, in India, only IECEx certificate of conformity for "d" is applicable.	

### Surface temperature of ZR22S (ATEX, IECEx, GB EX)

- Process temperature range for combustion (burning) process: -20°C to +700°C

#### ATEX, IECEx, GB EX

Temperature class or Maximum surface temperature	Maximum process flange temperature	Maximum terminal compartment temperature
T2 or T300°C	290°C	150°C
T3	190°C	150°C
T4	125°C	115°C

- Process temperature range for normal process: Ambient temperature

#### ATEX, IECEx

Temperature class or Maximum surface temperature
T3...T2 or T300°C, T4: Not available

#### GB EX

Temperature class or Maximum surface temperature
T2...T3 or T300°C, T4: Not available

### Surface temperature of ZR202S (ATEX, IECEx)

- Process temperature range for combustion (burning) process: -20°C to +700°C

Temperature class or Maximum surface temperature	Maximum process flange temperature	Maximum converter electronics enclosure temperature
T2 or T300°C	290°C	70°C

- Process temperature range for normal process: Ambient temperature

Temperature class or Maximum surface temperature
T2 or T300°C

## 1. ZR22S Explosion-proof Zirconia Oxygen Analyzer, Detector

- Sample Gas Temperature:  
0 to 700°C (Probe only)  
It is necessary to mount the cell using Inconel cell-bolts when the temperature is greater than 600°C.  
700 to 1400°C (with High Temperature Probe Adapter)
- For high-temperature sample gas, apply 0.15m length probe and High Temperature Probe Adapter ZO21P-H.  
A flame arrester may corrode if sample gas contains the following corrosive gases under 380°C or over.  
Greater than 5000 ppm SO<sub>2</sub>  
Greater than 1000 ppm NO  
Greater than 50 ppm HCl
- Sample Gas Pressure:  
-5 to +5 kPa  
For 0.15m probe, -0.5 to +5 kPa.  
No pressure fluctuation in the furnace should be allowed.
- Oxygen concentration of sample gas :  
For explosion-proof use, not more than that found in normal air, typically 21 vol%
- Probe Length: 0.15, 0.4, 0.7, 1.0, 1.5, 2.0 m  
Probe Material: SUS316 (JIS)
- Ambient Temperature:  
-20 to +60°C
- Surface Temperature:  
ATEX, IECEx and GB EX: Refer to Page7-9:Explosion-proof Approval.  
Other than ATEX, IECEx and GB EX:  
Maximum process flange temperature:300°C  
Maximum terminal compartment temperature:150°C
- Reference Gas System: Instrument Air  
Instrument Air System:  
Pressure; 50 kPa plus the pressure inside the furnace (It is recommended to use air which has been dehumidified by cooling to dew point -20°C or less, and dust or oil mist removed.)  
Consumption; Approx. 1 NI/min
- Oxygen concentration of calibration gas:  
For explosion-proof use, not more than that found in normal air, typically 21 vol%
- Wetted Material:  
SUS316 (JIS), Zirconia, SUS304 (JIS) or ASTM grade 304 (flange), Hastelloy B, (Inconel 600, 601)
- Construction:  
Heater and thermocouple replaceable construction.  
Equivalent to NEMA 4X/IP66. (Achieved when pipes are installed at calibration gas and reference gas inlets and pipe is installed so that reference gas can be exhausted to clean atmosphere. Excluding probe top. And achieved when the cable entry is completely sealed with a cable gland.)
- Terminal Box Case:  
Material; Aluminum alloy

- Terminal Box Paint Color:  
Case: Mint green (Munsell 5.6BG3.3/2.9)  
Cover: Mint green (Munsell 5.6BG3.3/2.9)
- Finish: Polyurethane corrosion-resistance coating
- Gas Connection:  
Rc1/4 or 1/4 NPT (Female)
- Wiring Connection:  
ATEX; M20 × 1.5 or 1/2 NPT select one type (2 pieces)  
FM; 1/2 NPT (2 pieces)  
CSA; 1/2 NPT (2 pieces)  
IECEx, GB EX; M20 × 1.5 or 1/2 NPT select one type (2 pieces)
- Installation: Flange mounting
- Probe Mounting Angle:  
Installing at angles from horizontal to vertical downward is possible.
- Weight:  
Probe length of 0.4 m: approx. 13 kg (ANSI 150 4)  
Probe length of 0.7 m: approx. 14 kg (ANSI 150 4)  
Probe length of 1.0 m: approx. 15 kg (ANSI 150 4)  
Probe length of 1.5 m: approx. 17 kg (ANSI 150 4)  
Probe length of 2.0 m: approx. 19 kg (ANSI 150 4)
- Available Converter:  
ZR402G, ZR802S, ZR802G, AV550G  
Only for connection to converter type ZR402G, ZR802G, ZR802S or AV550G according to the user manual.

## 2. ZR802S Explosion-proof Zirconia Oxygen Analyzer, Converter

- Display: LCD color display of size 320 by 240 dot with touchscreen
- Operation: Touch screen operation when the door is open.
- Analog Output:  
Number of points; Two points (input-output isolation)  
Output signal;  
  - 4 to 20 mA DC linear or log can be selected (maximum load resistance 550 Ω)
  - HART7 Communication (maximum load resistance 550 Ω)
  - Burn out signal according to NAMUR NE43.
- Output range;  
Oxygen concentration; Any setting between 0 to 5 through 0 to 100 vol% O<sub>2</sub> in 1 vol% O<sub>2</sub>, or partial range is available.  
For the log output, the minimum range value is fixed at 0.1 vol% O<sub>2</sub>.
- Output damping;  
0 to 255 seconds. Hold/non-hold selection, preset value setting possible with hold.
- Analog Input:  
Number of points;  
one point (for Pressure compensated)
- Input signal;  
4 to 20 mA DC (maximum 40 mA)
  - Converter power supply (standard) voltage; 16.6 to 25.2 V
  - With no power supply (option)

**Digital Communication:**

- HART7; AO1, 250 to 550  $\Omega$   
 Ethernet (Modbus TCP);  
 10/100 Mbps, Cable length Max.100 m,  
 grounding the shield  
 RS-485 (Modbus RTU);  
 115200/38400/9600 bps, Cable length  
 Max.600 m (115200 bps) Max.1200 m  
 (38400/9600 bps) grounding the shield

**Contact Output:**

- Number of points;  
 Four points (one is fail-safe, normally open)  
 • For DO-1/DO-2/DO-3, select either one,  
 normally energized (normally closed) or  
 normally de-energized (normally open)  
 status. (Open when power is on.)  
 • DO-4 is fail-safe. (ON at Fault or Failure of  
 NE107 setting), fixed normally energized  
 (normally open, closed at power-off).

**Contact capacity:**

30VDC 3A or 250VAC 3 A (load resistance)

Contact output for automatic calibration (Contact  
 output for explosion-proof solenoid valve supplied  
 by customer):

Two points; zero +/-, span +/-  
 Contact capacity; 250 V AC 0.6A (driven  
 by supply voltage to the converter)

- Function; Fault, High-high alarm, High alarm, Low-  
 low alarm, Low alarm, Maintenance,  
 Calibration, Range switching answer-  
 back, Warm-up, Calibration gas  
 pressure decrease (answer-back  
 of contact input), Temperature high  
 alarm, Blowback start, Flameout gas  
 detection (answer-back of contact input),  
 Calibration coefficient alarm, Startup  
 power stabilization timeout alarm,  
 Simple cell resistance alarm, With  
 simple cell resist. meas.

**Contact Input:**

- Number of points;  
 Two points (No-voltage contact input or  
 Transistor contact input )

**On/Off detection;**

- No-voltage contact input  
 Resistivity value 200  $\Omega$  or less; closed  
 Resistivity value 100 k $\Omega$  or above; open
- Transistor contact input  
 Voltage -1 to +1 VDC; closed,  
 Voltage value 4.5 to +25 VDC or  
 above; open

**Contact capacity;**

Off-state leakage current 3 mA or less

- Function; Calibration gas pressure decrease  
 alarm, Range switching, External  
 calibration start, Flameout gas detection,  
 (ON: heater shut-off and span calibration  
 gas inflow), Blowback start, Reboot

**Environmental condition:**

Ambient Temperature; -20 to +55°C  
 Storage Temperature; -30 to +70°C  
 Humidity; 10 to 90% RH at 40°C (Non-condensing)

**Power Supply Voltage:**

Ratings; 100 to 240 V AC  
 Acceptable range; 85 to 264 V AC

**Power Supply Frequency:**

Ratings; 50/60 Hz  
 Acceptable range; 47 to 63 Hz

**Power Consumption:**

Max. 800 VA, approx. 330 VA for ordinary  
 use.

**Power supply 100V AC:**

Max. 160 VA (160 W), approx. 120 VA  
 (approx. 100 W) for ordinary use

**Power supply 230 V AC:**

Max 550 VA (370 W), approx. 260 VA  
 (approx. 100 W)

**Maximum Distance between Detector and Converter:**

Conductor two-way resistance must be  
 10  $\Omega$  or less (when a 1.25 mm<sup>2</sup> cable or  
 equivalent is used, 300 m or less.)

**Construction:**

Equivalent to NEMA/CSA TYPE 4X, IP66  
 (with conduit holes completely sealed with  
 a cable gland)

**Wiring Connection: eight holes**

Type; G1/2, M20  $\times$  1.5 mm, Pg13.5, 1/2NPT

**Installation: Wall or 2-inch pipe mounting****Material:**

Case; Aluminum alloy

Window; glass

**Paint Color: Mint green (equivalent to RAL 190 30 15)****Finish: Polyurethane corrosion-resistance coating****Weight: Approx. 16 kg****Functions****Display Functions:****Value Display;**

Displays values of the measured oxygen  
 concentration, etc.

**Graph Display;**

Displays trends of measured oxygen  
 concentration and the test result from a  
 cell resistance tester.

**Data Display;**

Displays various useful data for  
 maintenance, such as cell temperature,  
 reference junction temperature,  
 maximum/minimum oxygen  
 concentration, or the like

**Status Message;**

Indicates an alarm or error occurrence  
 by flashing of the corresponding icon.  
 Indicates status such as warming-up,  
 calibrating, or the like by the marks.

**Alarm Display;**

Alarm name, description,  
 Countermeasures display at error  
 occurrence, NAMUR NE107 compliant  
 4-symbol display

**Calibration Functions:****Calibration method;**

Zero/span calibration (Either zero or  
 span can be skipped)

**Calibration mode;**

- Automatic Calibration; Explosion-  
 proof solenoid valves must be  
 provided by customer. It calibrates  
 automatically at specified intervals.
- Semi-automatic Calibration;  
 Explosion-proof solenoid valves  
 must be provided by customer.  
 Input calibration direction on the  
 touchscreen or contact, then it  
 calibrates automatically afterwards.

<ul style="list-style-type: none"> <li>• Manual Calibration; Calibration with opening/closing the valve of calibration gas in operation interactively with an LCD touchscreen.</li> </ul>	<p>Graph Display; Displays trends of test result of resistivity from a cell resistance tester</p>
<p>Calibration gas setting;</p> <ul style="list-style-type: none"> <li>• Zero calibration gas concentration setting range; 0.3 to 21 vol% O<sub>2</sub> (minimum setting; 0.01 vol% O<sub>2</sub>)</li> <li>• Span calibration gas concentration setting range; 4.5 to 21 vol% O<sub>2</sub> (minimum setting; 0.01 vol% O<sub>2</sub>)</li> </ul> <p>Use N<sub>2</sub>-balanced mixed gas containing 0 to 10% scale of oxygen, and 80 to 100 % scale of oxygen for standard zero gas and standard span gas respectively.</p>	<p>SD card output; Measurement log (date/time, oxygen concentration, cell e.m.f, test result from a cell resistance tester, cell condition, NE107 status, etc.) Maintenance report (setup value, calibration value etc.) can be saved to SD cards in CSV format. The stored data can be copied to other converter by outputting user-setting parameters to SD cards.</p>
<p>Calibration interval; date/time setting (Max. 255 days)</p>	<p>Sensor Self-diagnosis Function: Calibration mode diagnose; Span/Zero compensation rate, cell response time, cell condition</p>
<p>Purging Function: Before warming up the detector, feed the span gas for the set period of time to drain condensed water out of the piping of calibration gas. Detector's warming-up starts after the set period of purging time elapses.</p>	<p>Cell resistance test ; result from a cell resistance test without feeding calibration gas</p> <ul style="list-style-type: none"> <li>• Measurement mode; auto cell resistance test, semi-auto cell resistance test,</li> <li>• Cell resistance test setting; stabilization time (min. sec.) starting time (year/month/date/hour/minute) measurement interval (day/time)</li> </ul>
<p>Blowback Function: To allow a periodic purging etc., open/close contact output in the set period of interval or time defined full/semi-automatically.</p>	<p><b>Display and setting content:</b> Measuring Related Items: Oxygen concentration (vol% O<sub>2</sub>), output current value</p>
<p>Fault: Alarm Function; The occurrence of Fault alarm stops the power supply to the heater. Fault alarm keeps turning on until the power shuts down.</p>	<p>Display Items: Cell temperature (°C), thermocouple reference junction temperature (°C), maximum/minimum/average oxygen concentration (vol% O<sub>2</sub>), cell e.m.f. (mV), cell internal resistance (Ω), cell condition (in four grades), heater on-time rate (%), calibration record (twenty times), time (year/month/day, hour/minute)</p>
<p>Type; Cell voltage failure, Heater temperature failure, A/D converter failure, Memory failure, Hardware error, data redundancy mismatch</p>	<p>Calibration Setting Items: Span gas concentration (vol% O<sub>2</sub>), zero gas concentration (vol% O<sub>2</sub>), calibration mode (automatic, semi-automatic, manual), calibration type and method (zero-span calibration, zero calibration only, span calibration only), stabilization time (min. sec), calibration time (min. sec), calibration interval (day/hour), starting time (year/month/day, hour/minute)</p>
<p>Alarm: Function; Alarm keeps turning on until potential causes of a problem are eliminated.</p>	<p>Output Related Items: Analog output/output mode selection, output conditions when warming-up/maintenance/calibrating (during blowback)/abnormal, oxygen concentration at 4 mA/20 mA (vol% O<sub>2</sub>), time constant.</p>
<p>Type; Oxygen concentration alarm, Zero-point calibration coefficient alarm, Span-point calibration coefficient alarm, EMF stabilization time-up alarm, Cold junction temperature alarm, Thermocouple voltage alarm, Input current alarm, Battery low alarm, Input-pressure alarm, Cell resistance alarm</p>	<p>Alarm Related Items: Oxygen concentration high alarm/high-high alarm limit values (vol% O<sub>2</sub>), oxygen concentration low alarm/low-low alarm limit values (vol% O<sub>2</sub>), oxygen concentration alarm hysteresis (vol% O<sub>2</sub>), oxygen concentration alarm detection, alarm delay (seconds)</p>
<p>NAMUR NE 107 Alarm Display Function: Displays 4 warnings of NAMUR NE 107 standard; F: Failure (Fault equivalent, Power supply to the heater shuts down.) C: Function Check S: Out of Specification M: Maintenance Required</p>	
<p>Data Logging Function: Stores following data to SD card or visualizes on the instrument display. SD cards which are recommended or equivalent must be supplied by customer,</p>	
<p>Event display; Log of Alarms, Calibration Trend, Power-on history are displayed on the main unit.</p>	

**Contact Related Items:**

Selection of contact input 1 and 2, selection of contact output 1 to 3 (Fault, high-high alarm, high alarm, low alarm, low-low alarm, maintenance, calibrating, range switching, warming-up, calibration gas pressure decrease, temperature high alarm, temperature high alarm, pressure high alarm, pressure low alarm, test result from a cell resistance tester, alarm of a cell resistance tester, calibration coefficient alarm, cell e.m.f. stabilization time over blowback, flameout gas detection)

**3. ZR202S Integrated type Explosion-proof Zirconia Oxygen Analyzer**

Display: 6-digit LCD

Switch: Three optical switches

Output Signal:

4 to 20 mA DC, one point (maximum load resistance 550  $\Omega$ )

Digital Communication (HART):

250 to 550  $\Omega$ , depending on quantity of field devices connected to the loop (multi-drop mode).

Contact Output Signal:

Two points (one is fail-safe, normally open)

Contact Input Signal: Two points

Sample Gas Temperature: 0 to 700°C

It is necessary to mount the cell using Inconel cell-bolts when the temperature measures more than 600°C.

High-temperature service – greater than 700°C – is not available.

A flame arrester may corrode if sample gas contains the following corrosive gases under 380°C or over.

Greater than 5000 ppm SO<sub>2</sub>

Greater than 1000 ppm NO

Greater than 50 ppm HCl

Sample Gas Pressure:

- 5 to + 5 kPa

No pressure fluctuation in the furnace should be allowed.

Oxygen concentration of sample gas:

For explosion-proof use, not more than that found in normal air, typically 21 vol%

Probe Length: 0.4, 0.7, 1.0, 1.5, 2.0 m

Probe Material: SUS316 (JIS)

Ambient Temperature:

-20 to +55°C

Surface Temperature:

ATEX and IECEx: Refer to Page7:Explosion-proof Approval.

Other than ATEX and IECEx:

Maximum process flange temperature:300°C

Maximum terminal compartment temperature:70°C

Storage Temperature: -30 to +70°C

Ambient Humidity: 0 to 95%RH (non-condensing)

Power Supply Voltage:

Ratings; 100 to 240 V AC

Acceptable range; 85 to 264 V AC

Power Supply Frequency:

Ratings; 50/60 Hz

Acceptable range; 45 to 66 Hz

Power Consumption:

Max. 300 W, approx. 100 W for ordinary use.

Reference Gas System: Instrument Air

Instrument Air System:

Pressure;50 kPa + the pressure inside the furnace 150 kPa + the pressure inside the furnace with automatic calibration unit.

(It is recommended to use air which has been dehumidified by cooling to dew point -20°C or less, and filtering to remove dust or oil mist.)

Consumption; Approx. 1.5 NI/min

Oxygen concentration of calibration gas:

For explosion-proof use, not more than that found in normal air, typically 21 vol%

<p><b>Wetted Material:</b> SUS316 (JIS), Zirconia, SUS304 (JIS) or ASTM grade 304 (flange), Hastelloy B, (Inconel 600, 601)</p> <p><b>Construction:</b> Heater and thermocouple replaceable construction. Equivalent to NEMA 4X/IP66. (Achieved when pipes are installed at calibration gas and reference gas inlet and exhaust pipe is installed so that reference gas can be exhausted to clean atmosphere. Excluding probe top.) (Achieved when the cable entry is completely sealed with a cable gland.)</p> <p><b>Gas Connection:</b> Rc1/4 or 1/4 NPT (Female)</p> <p><b>Wiring Connection:</b> ATEX; M20 × 1.5, 1/2 NPT select one type (4 pieces) FM; 1/2 NPT (4 pieces) CSA; 1/2 NPT (4 pieces) IECEX; M20 × 1.5 or 1/2 NPT select one type (4 pieces)</p> <p><b>Installation:</b> Flange mounting</p> <p><b>Probe Mounting Angle:</b> Horizontal to vertically downward. Installing at angles from horizontal to vertical downward is available.</p> <p><b>Case:</b> Aluminum alloy</p> <p><b>Paint Color:</b> Cover; Mint green (Munsell 5.6BG3.3/2.9) Case; Mint green (Munsell 5.6BG3.3/2.9)</p> <p><b>Finish:</b> Polyurethane corrosion-resistance coating</p> <p><b>Weight:</b> Probe length of 0.4 m: approx. 15 kg (ANSI 150 4) Probe length of 0.7 m: approx. 16 kg (ANSI 150 4) Probe length of 1.0 m: approx. 17 kg (ANSI 150 4) Probe length of 1.5 m: approx. 19 kg (ANSI 150 4) Probe length of 2.0 m: approx. 21 kg (ANSI 150 4)</p> <p><b>Functions</b></p> <p><b>Display Function:</b> Displays values of the measured oxygen concentration, etc.</p> <p><b>Alarm, Error Display:</b> Displays alarms such as "AL-06" or errors such as "Err -01" when any such status occurs.</p> <p><b>Calibration Functions:</b> <b>Automatic Calibration;</b> Requires the Auto-calibration Unit. It calibrates automatically at specified intervals. <b>Semi-automatic Calibration;</b> Requires the Automatic Calibration Unit. Input calibration start signal by optical switch or contact, then it calibrates automatically afterwards. <b>Manual Calibration;</b> Calibration with opening/closing the valve of calibration gas in operation interactively with the optical switch.</p> <p><b>Maintenance Functions:</b> Can operate updated data settings in daily operation and checking. Display data settings, calibration data settings, test settings (current output loop check, input/output contact check).</p>	<p><b>Setup Functions:</b> Initial settings suit for the plant conditions when installing the converter. Current output data settings, alarm data settings, contact data settings, other settings.</p> <p><b>Display and setting content:</b> <b>Display Related Items:</b> Oxygen concentration (vol%O<sub>2</sub>), Output current value (mA), air ratio, moisture quantity (in hot gases) (vol%H<sub>2</sub>O), Cell temperature (°C), thermocouple reference junction temperature (°C), maximum/minimum/average oxygen concentration (vol% O<sub>2</sub>), cell e.m.f. (mV), cell internal resistance (Ω), cell condition (in four grades), heater on-time rate (%), calibration record (ten times), time (year/month/day, hour/minute)</p> <p><b>Calibration Setting Items:</b> Span gas concentration (vol% O<sub>2</sub>), zero gas concentration (vol% O<sub>2</sub>), calibration mode (automatic, semi-automatic, manual), calibration type and method (zero-span calibration, zero calibration only, span calibration only), stabilization time (min. sec), calibration time (min. sec), calibration period (day/hour), starting time (year/month/day/hour/minute)</p> <p><b>Output Related Items:</b> Analog output/output mode selection, output conditions when warming-up/maintenance/calibrating/abnormal, 4 mA/20 mA point oxygen concentration (vol% O<sub>2</sub>), time constant.</p> <p><b>Alarm Related Items:</b> Oxygen concentration high alarm/high-high alarm limit values (vol% O<sub>2</sub>), Oxygen concentration low alarm/low-low alarm limit values (vol%O<sub>2</sub>), Oxygen concentration alarm hysteresis (vol%O<sub>2</sub>), Oxygen concentration alarm detection, alarm delay (seconds)</p> <p><b>Contact Related Items:</b> Selection of contact input 1 and 2, selection of contact output 1 and 2 (abnormal, high-high alarm, high alarm, low alarm, low-low alarm, maintenance, calibrating, range switching, warming-up, calibration gas pressure decrease, flameout gas detection (answerback of contact input)</p> <p><b>Converter Output:</b> One mA analog output (4 to 20 mA DC (maximum load resistance of 550 Ω)) with mA digital output point (HART) (minimum load resistance of 250 Ω). Range: Any setting between 0 to 5 through 0 to 100 vol%O<sub>2</sub> in 1 vol%O<sub>2</sub>, or partial range is available (Maximum range value/ minimum range value 1.3 or more) For the log output, the minimum range value is fixed at 0.1 vol%O<sub>2</sub>. 4 to 20 mA DC linear or log can be selected. Input/output isolation provided.</p> <p><b>Output damping:</b> 0 to 255 seconds. Hold/non-hold selection, preset value setting possible with hold.</p>
--	--

**Contact Output:**

Two points, contact capacity 30 V DC 3 A, 250 V AC 3 A (resistive load)

One of the output points can be selected to either normally energized or normally de-energized status.

Delayed functions (0 to 255 seconds) and hysteresis function (0 to 9.9 vol%O<sub>2</sub>) can be added to high/low alarms.

The following functions are programmable for contact outputs.

- (1) Abnormal,
- (2) High high alarm,
- (3) High alarm,
- (4) Low-low alarm,
- (5) Low alarm,
- (6) Maintenance,
- (7) Calibration,
- (8) Range switching answer-back,
- (9) Warming-up,
- (10) Calibration gas pressure decrease (answer-back of contact input),
- (11) Flameout gas detection (answer-back of contact input).

Contact output 2 is set to normally operated, fixed error status.

**Contact Input:**

Two points, voltage-free contacts

The following functions are programmable for contact inputs:

- (1) Calibration gas pressure decrease alarm,
- (2) Range switching (switched range is fixed),
- (3) External calibration start,
- (4) Process alarm (if this signal is received, the heater power turns off)

**Self-diagnosis:**

Abnormal cell, abnormal cell temperature (low/high), abnormal calibration, A/D converter abnormal, digital circuit abnormal

**Calibration: Method; zero/span calibration**

Calibration mode; automatic, semi-automatic and manual (All are operated using optical switches). Either zero or span can be skipped.

Zero calibration gas concentration setting range: 0.3 to 100 vol%O<sub>2</sub> (in 0.01 vol%O<sub>2</sub>).

Span calibration gas concentration setting range: 4.5 to 100 vol%O<sub>2</sub> (in 0.01 vol%O<sub>2</sub>).

Use N<sub>2</sub>-balanced mixed gas containing 10 vol%O<sub>2</sub> scale of oxygen for standard zero gas, and 80 to 100 vol%O<sub>2</sub> scale of oxygen for standard span gas.

Calibration period; date/time setting: maximum 255 days

**■ OPTIONS****4. ZO21P Probe Adapter for ZR22S**

Measuring O<sub>2</sub> in the high temperature gases (exceeds 700°C) requires a general-use probe ZR22S of 0.15 m length and a high temperature probe adapter.

Sample gas temperature:

0 to 1400°C (when using SiC probe) 0 to 800°C (when using SUS310S probe adapter)

Sample gas pressure:

-0.5 to + 5 kPa. When using in the range of 0 to 25 vol%O<sub>2</sub> or more, the sample gas pressure should be in the range of -0.5 to +0.5 kPa. (Where the sample gas pressure for the high-temperature probe is negative, an ejector assembly is necessary.)

Insertion length:

0.5, 0.6, 0.7, 0.8, 0.9, 1.0, 1.5 m

Material in Contact with Gas:

SUS316 (JIS), SiC or SUS310S, SUS304 (JIS) or ASTM grade 304 (flange)

Probe Material:

SiC, SUS310S (JIS)

Installation: Flange mounting (FF type or RF type)

Probe Mounting Angle:

Vertically downward within ± 5°.

Where the probe material is SUS310S, horizontal mounting is available.

Construction:

Non explosion-proof. Rainproof construction

Weight(example):

Insertion length of 1.0 m: approx. 5.3 kg (JIS) / approx. 11.3 kg (ANSI)

Insertion length of 1.5 m:

approx. 5.8 kg (JIS) / approx. 11.8 kg (ANSI)

**5. Ejector Assembly for High Temperature Probe of Oxygen Analyzer (E7046EC/E7046EN)**

For use in cases where pressure of sample gas for high temperature detector is negative.

**5.1 Needle Valve**

Connection: Rc1/4 or 1/4 NPT (Female)

Material: SUS316 (JIS)

(Note) Pipes and connectors are not provided.

**5.2 Pressure Gauge Assembly**

Material in Contact with Gas: SUS316 (JIS)

Case Material: Aluminum alloy (Paint color; black)

Scale: 0 to 100 kPaG

Connection: R1/4 or 1/4 NPT, SUS304 (JIS) (with Bushing G3/8 × R1/4 or 1/4 NPT)

**5.3 Ejector**

Ejector Inlet Air Pressure: 29 to 69 kPaG

Air Consumption: Approx. 30 to 40 l/min

Suction gas flow rate: 3 to 7 l/min

Connection: Rc1/4, SUS304 (JIS)

Tube Connection: (Ø6/Ø4 mm or 1/4 inch copper tube or stainless tube)

## 6. ZO21R Probe Protector for Zirconia Oxygen Analyzer

Used when sample gas flow velocity is approx. 10 m/sec or more and dust particles wears the detector in cases such as pulverized coal boiler of fluidized bed furnace (or burner) to protect the detector from wearing by dust particles.

Insertion Length: 1.05 m, 1.55 m, 2.05 m  
 Flange: JIS 5K 65A FF equivalent. ANSI Class 150 4 FF (without serration) equivalent. However, flange thickness is different.  
 Material: SUS316 (JIS), SUS304 (JIS) or ASTM grade 304 (Flange)  
 Weight: 1.05 m; Approx. 6/10 kg (JIS/ANSI)  
 1.55 m; Approx. 9/13 kg (JIS/ANSI)  
 2.05 m; Approx. 12/16 kg (JIS/ANSI)  
 Installation: Bolts, nuts, and washers are provided for detector, probe adapter and process-side flange.

## 7. ZA8F Flow Setting Unit for manual calibration

Used when instrument air is provided.

This unit consists of flowmeters and flow control valves to control the flow rates of calibration gas and reference gas.

Flowmeter Scale: Calibration gas; 0.1 to 1.0 l/min.  
 Reference gas; 0.1 to 1.0 l/min.  
 Construction: Dust-proof and rainproof construction  
 Case Material: SPCC (Cold rolled steel sheet)  
 Painting: Baked epoxy resin, Dark-green (Munsell 2.0 GY 3.1/0.5 or equivalent)  
 Tube Connections: Rc1/4 or 1/4 NPT (Female)  
 Reference Gas Pressure: Clean air supply of sample gas pressure plus approx. 50 kPaG (or sample gas pressure plus approx. 150kPa when a check valve is used.). Pressure at inlet of the Flow Setting Unit. (Max. 300 kPaG).  
 Air Consumption: Approx. 1.5 l/min  
 Weight: Approx. 2.3 kg

## 8. Stop Valve for Calibration gas line (L9852CB/G7016XH)

The stop valve is mounted on the calibration gas line. To include Nipple Stop Valve with the product, select the suffix code (/SV) for ZR22S Separate type Explosion-proof Zirconia Oxygen Analyzer, Detector or ZR202S Integrated type Explosion-proof Zirconia Oxygen Analyzer.

Connection: Rc1/4 (L9852CB) or 1/4 NPT (F) (G7016XH)  
 Material: SUS316 (JIS)  
 Weight: Approx. 150 g

## 9. Check Valve for Calibration gas line (K9292DN/K9292DS)

This is used to prevent entry of sample gas into calibration gas line. Purpose is the same as stop valve, but is convenient, as it does not need to be opened or closed for calibration.

Mount directly on calibration gas inlet of detector in place of stop valve. However as source pressure of 150 kPaG or more is needed, standard gas unit cannot be used.

When option code "/CV" of the ZR22S or the ZR202S is specified, check valve is provided.

Connection: Rc1/4 (K9292DN) or 1/4 NPT (F) (K9292DS)  
 Material: SUS304 (JIS)  
 Pressure: 70 kPaG or more and 350 kPaG or less  
 Weight: Approx. 90g

## 10. Air Set

This set is used to lower the pressure when instrument air is used as the reference and span gases.

### G7003XF/K9473XK

Primary Pressure: Max. 1 MPaG  
 Secondary Pressure: 0.02 to 0.2 MPaG  
 Connection: Rc1/4 or 1/4 NPT (F) with joint adapter  
 Weight: Approx. 1 kg

### G7004XF/K9473XG

Primary Pressure: Max. 1 MPaG  
 Secondary Pressure: 0.02 to 0.5 MPaG  
 Connection: Rc1/4 or 1/4 NPT (F) with joint adapter  
 Weight: Approx. 1 kg

## 11. Pressure Regulator for Gas Cylinder (G7013XF/G7014XF)

Primary Pressure: 14.8 MPaG,  
 Secondary Pressure: 0 to 0.4 MPaG  
 Connection: Inlet; W22 14 threads, right hand screw Outlet; Rc1/4 or 1/4 NPT (Female)  
 Material: Brass body

## 12. ZR22A, ZR202A Heater Assembly

ZR22A: Spare Parts for ZR22S  
 ZR202A: Spare Parts for ZR202S  
 (Note) Yokogawa shall not guarantee the heater assembly after its replacement.

## 13. Calibration Gas Unit Case (E7044KF)

Installation: 2B pipe mounting  
 Material: SPCC (Cold rolled steel sheet)  
 Case Paint: Baked epoxy resin, Jade green (Munsell 7.5 BG 4/1.5)  
 Weight: Approx. 10 kg with gas cylinder  
 (Note) Export of such high pressure filled gas cylinders to most countries is prohibited or restricted.

## Model and Suffix Codes

### 1. Explosion-proof Zirconia Oxygen Analyzer, Detector

Model	Suffix code	Option code	Description
ZR22S	-----	-----	Separate type Explosion-proof Zirconia Oxygen Analyzer, Detector
Explosion-proof Approval (*1)	-A -B -C -D -Q -R -K -M	----- ----- ----- ----- ----- ----- ----- -----	ATEX certified flameproof (*2) FM certified explosion-proof CSA certified explosion-proof IECEX certified flameproof (*2) (*3) EAC certified explosion-proof with PA (*4) EAC certified explosion-proof without PA (*4) Korea Ex certification GB EX certificated flameproof (by NEPSI) (*16)
Length	-015 -040 -070 -100 -150 -200	----- ----- ----- ----- ----- -----	0.15 m (*5) 0.4 m 0.7 m 1.0 m 1.5 m 2.0 m
Wetted material	-S -C	----- -----	Stainless steel Stainless steel with Inconel calibration gas tube (*6)
Flange (*7)	-A -B -C -E -F -G -K -L -M -P -Q -R -S -W	----- ----- ----- ----- ----- ----- ----- ----- ----- ----- ----- ----- ----- -----	ANSI Class 150 2 RF (*8) ANSI Class 150 3 RF ANSI Class 150 4 RF (*8) DIN PN10 DN50 A DIN PN10 DN80 A DIN PN10 DN100 A JIS 5K 65 FF JIS 10K 65 FF JIS 10K 80 FF JIS 10K 100 FF JIS 5K 32 FF (for high temperature use) (*9) JPI Class 150 4 RF JPI Class 150 3 RF Westinghouse
Reference gas	-E	-----	External connection (Instrument air) (*10)
Gas thread	-R -T	----- -----	Rc1/4 1/4 NPT (Female)
Connection box thread	-M -T	----- -----	M20 x1.5 mm 1/2 NPT (*11)
Instruction manual	-E -K	----- -----	English Korea (*12)
—	-A	-----	Always -A
Options	Valves Tag plates	/C /CV /SV /SCT /PT	Inconel bolt (*13) Check valve (*14) Stop valve (*14) Stainless steel tag plate (*15) Printed tag plate (*15)

- \*1: When using ZR22S as CE marking compliance product, select -A (ATEX certified flameproof).
- \*2: The cable entry devices (cable glands etc.) and blind plugs shall be certified in type of protection Ex “d(db) IIC” or Ex “tb IIC” according to the applicable regulatory requirement: ATEX (-A), IECEX (-D), suitable for the conditions of use and correctly installed. They shall provide a degree of ingress protection of at least IP66.
- \*3: Product registration is done by Yokogawa Taiwan Corporation as an importer in Taiwan.
- \*4: Please select -Q for final destination of Russian Federation.  
Please select -R for final destination of Kazakhstan and Belarus.  
For more information about certification availability, please contact Yokogawa office.
- \*5: For a high temperature detector, use with the ZO21P Probe Adapter and select Flange -Q.
- \*6: Recommended if sample gas contains corrosive gas like chlorine.
- \*7: The thickness of the flange depends on its dimensions.
- \*8: Confirm inside diameter of pipe attached to customer's flange in case that -A or -E is selected.
- \*9: The flange thickness does not conform to JIS specification.
- \*10: Piping for reference gas must be installed to supply reference gas constantly at a specified flow rate.
- \*11: When selecting code -B (FM certified explosion-proof) or -C (CSA certified explosion-proof), select code -T (1/2 NPT).
- \*12: If you want to order Korea Ex specification, please select -K.
- \*13: Inconel probe bolts and U shape pipe are used. Use this option for high temperature use (ranging from 600 to 700°C).
- \*14: Specify either /CV or /SV option code.
- \*15: Specify either /SCT or /PT option code.
- \*16: M20X1.5 or 1/2 NPT thread type cable entry, adapters and/or blanking elements, certified by notified body with type of protection Ex db IIC Gb in accordance with GB/T 3836.1-2021 and GB/T 3836.2-2021, should be applied when installation in explosive gas atmosphere. The IP code should be IP66. M20X1.5 or 1/2 NPT thread type cable entry, adapters and/or blanking elements, certified by notified body with type of protection Ex tb IIC Db in accordance with GB/T 3836.1-2021 and GB/T 3836.31-2021, should be applied when installation in combustible dust atmosphere. The IP code should be IP66.

### Standard Accessory

Item	Q'ty	Description
Allen wrench	1	For lock screw

## 2. Explosion-proof Zirconia Oxygen Analyzer, Converter

Model	Suffix code	Option code	Description
ZR802S	-----	-----	Explosion-proof Zirconia Oxygen Analyzer, Converter
Conformity in Hazardous location	-A	-----	EU -Type Examination certificate of conformity for "d" and "t" (ATEX) (*1)
	-B	-----	US certificate of conformity for "d", "t", and Class I, II, III Division 1 (by FM) (*2)
	-C	-----	Canadian certificate of conformity for "d" and "t" (CSA) (*2)
	-D	-----	IECEX certificate of conformity for "d" and "t" (*1) (*3)
	-K	-----	Korea Ex certificate of conformity for "d" and "t" (by KTL) (*1) (*4)
	-M	-----	China Ex certificate of conformity for "d" and "t" (by NEPSI) (*1) (*4)
	-Q	-----	EAC certified explosion-proof for "d" and "t" with PA (*1) (*4) (*5)
-R	-----	EAC certified explosion-proof for "d" and "t" without PA (*1) (*4) (*5)	
Converter thread	-M -T	----- -----	M20 x 1.5 mm 1/2 NPT
Digital communication	-H -M -E	----- ----- -----	HART HART+Modbus RS485 HART+Modbus Ethernet
—	-N	-----	Always -N
—	-N	-----	Always -N
Options		/SCT /H /CJ  /AI /AC /RC /JP	TAGNO. Engraved on the metal nameplate (*6) Awning hood Cold junction temperature compensation (with Pt1000 resistance thermometer) (*7) Analog input with no power supply With solenoid valve drive output for automatic calibration (*8) Rugged Coating (epoxy + urethane coating) Made in Japan (*4)

\*1: Only -M can be specified to the converter thread.

\*2: Only -T can be specified to the converter thread.

\*3: If you want to order Taiwan Ex specification, please select -D. (Taiwan Ex registration based on IECEx)  
If you want to order Indian Ex specification, please select -D. (Indian Ex approval based on IECEx)  
However, in India, only IECEx certificate of conformity for "d" is applicable.

\*4: If /JP is not selected, it is made in China.  
/JP cannot be specified for Korea Ex (-K), China Ex (-M), EAC Ex with PA (-Q) and EAC Ex without PA (-R).

\*5: Please select -Q for final destination of Russian Federation.  
Please select -R for final destination of Kazakhstan and Belarus.  
For more information about certification availability, please contact Yokogawa office.

\*6: When suffix code except for /SCT is specified, it will be supplied the tag label with TAGNO. printed.

\*7: Connect the supplied Pt1000 resistance thermometer for cold junction temperature compensation to CJ terminal, when /CJ is specified.

\*8: Explosion-proof solenoid valves must be provided by customer.

### Standard Accessories

Item	Q'ty	Description
Fuse	1	3.15 A (Parts NO. A1113EF)
Fuse	2	2.5 A (Parts NO. A1112EF) (with /AC Option)
Bracket	1	For pipe mounting
U-bolt for pipe mounting	2	2B
Tag label (standard)	1	(Note 1)

(Note 1) Tag label is included when suffix code except for /SCT is specified.  
A blank label is included when no TAGNO. is specified.

**<Items specified at order>**

1. TAGNO. (only if necessary)  
 You can create TAGNO. (tag number) with alphanumeric characters described in the next table. 16 characters at maximum can be used.  
 If you specify TAGNO., it is displayed on the instrument screen, and is printed on the stainless name plate/tag label affixed to the instrument.

Symbol (Note)	-	Hyphen	_	Underscore
	=	Equal	+	Plus
	/	Slash	:	Colon
	(	Left parenthesis	)	Right parenthesis
	#	Hash	!	Exclamation mark
	.	Period		
Number	0, 1, 2, 3, 4, 5, 6, 7, 8, 9			
Upper case alphabets	A, B, C, D, E, F, G, H, I, J, K, L, M, N, O, P, Q, R, S, T, U, V, W, X, Y, Z			
lower case alphabets	a, b, c, d, e, f, g, h, i, j, k, l, m, n, o, p, q, r, s, t, u, v, w, x, y, z			

(Note) For ZR802S, if a space is specified for TAGNO, the space will be deleted and the setting will be left justified.

2. Language  
 English, Chinese, German, French, Portuguese, Russian, Japanese

**SD card (supplied by customer)**

Item	Q'ty	Parts No.	Description
SD card	1	773001	1 GB Customer may provide. 128 MB or above SD or SDHC

**3. Integrated type Explosion-proof Zirconia Oxygen Analyzer**

Model	Suffix code	Option code	Description
ZR202S	-----	-----	Integrated type Explosion-proof Zirconia Oxygen Analyzer
Explosion-proof Approval (*1)	-A	-----	ATEX certified flameproof (*2)
	-B	-----	FM certified explosion-proof
	-C	-----	CSA certified explosion-proof
	-D	-----	IECEX certified flameproof (*2)(*3)
	-Q	-----	EAC certified explosion-proof with PA (*4)
	-R	-----	EAC certified explosion-proof without PA (*4)
	-K	-----	Korea Ex certification
Length	-040	-----	0.4 m
	-070	-----	0.7 m
	-100	-----	1.0 m
	-150	-----	1.5 m
	-200	-----	2.0 m
Wetted material	-S	-----	Stainless steel
	-C	-----	Stainless steel with Inconel calibration gas tube (*5)
Flange (*6)	-A	-----	ANSI Class 150 2 RF (*7)
	-B	-----	ANSI Class 150 3 RF
	-C	-----	ANSI Class 150 4 RF
	-E	-----	DIN PN10 DN50 A (*7)
	-F	-----	DIN PN10 DN80 A
	-G	-----	DIN PN10 DN100 A
	-K	-----	JIS 5K 65 FF
	-L	-----	JIS 10K 65 FF
	-M	-----	JIS 10K 80 FF
	-P	-----	JIS 10K 100 FF
	-R	-----	JPI Class 150 4 RF
-S	-----	JPI Class 150 3 RF	
-W	-----	Westinghouse	
Automatic Calibration	-N	-----	Not required
	-A	-----	Horizontal mounting (*8)
	-B	-----	Vertical mounting (*8)
Reference gas	-E	-----	External connection (Instrument air) (*9)
Gas Thread	-R	-----	Rc1/4
	-T	-----	1/4 NPT (F)
Connection box thread	-M	-----	M20 x 1.5
	-T	-----	1/2 NPT (*10)
Instruction manual	-E	-----	English
	-K	-----	Korea (*11)
-	-A	-----	Always -A

Options		/C	Inconel bolt (*12)
	Valves	/CV	Check valve (*13)
		/SV	Stop valve (*13)
		/H	Hood (*14)
	Tag plates	/SCT	Stainless steel tag plate (*15)
		/PT	Printed tag plate (*15)
	NAMUR NE43 compliant	/C2	Failure alarm down-scale: Output status at CPU failure and hardware error is 3.6 mA or less (*16)
		/C3	Failure alarm up-scale: Output status at CPU failure and hardware error is 21.0 mA or more (*16)

- \*1 When using ZR202S as CE marking compliance product, select -A (ATEX certified flameproof).
- \*2 The cable entry devices (cable glands etc.) and blind plugs shall be in type of protection Ex "db" or Ex "tb", suitable for the conditions of use and correctly installed. They shall provide a degree of ingress protection of at least IP66.
- \*3 Product registration is done by Yokogawa Taiwan Corporation as an importer in Taiwan.  
If you want to order Indian Ex specification, please select -D. (Indian Ex approval based on IECEx).  
However, in India, only IECEx certificate of conformity for "d" is applicable.
- \*4 Please select -Q for final destination of Russian Federation.  
Please select -R for final destination of Kazakhstan and Belarus.  
For more information about certification availability, please contact Yokogawa office.
- \*5 Recommended if sample gas contains corrosive gas like chlorine.
- \*6 The thickness of the flange depends on its dimensions.
- \*7 Confirm inside diameter of pipe attached to customer's flange in case that -A or -E is selected.
- \*8 No need to specify the option codes, /CV and /SV, since the check valves are provided with the automatic calibration unit.
- \*9 Piping for reference gas must be installed to supply reference gas constantly at a specified flow rate.
- \*10 When selecting code -B (FM certified explosion-proof) or -C (CSA certified explosion-proof), select code -T(1/2 NPT).
- \*11 When selecting code -K (Korea Ex certification)
- \*12 Inconel probe bolts and U shape pipe are used. Use this option for high temperature use (ranging from 600 to 700°C).
- \*13 Specify either /CV or /SV option code.
- \*14 Sun shield hood is still effective even if scratched. Hood is necessary for outdoor installation out of sun shield roof.
- \*15 Specify either /SCT or /PT option code.
- \*16 Output signal limits: 3.8 to 20.5 mA. Specify either /C2 or /C3 option code.

#### Standard Accessories

Item	Q'ty	Description	Item	Q'ty	Description
Fuse	1	3.15A (Parts No. A1113EF)	Allen wrench	1	For lock screw

#### High Temperature Probes (Spare Parts)

#### 4. Probe Adapter for ZR22S

Model	Suffix code	Option code	Description
ZO21P	-H	-----	High Temperature Probe Adapter
Material	-A -B	----- -----	SiC SUS310S (JIS)
Insertion length	-050 -060 -070 -080 -090 -100 -150	----- ----- ----- ----- ----- ----- -----	0.5 m 0.6 m 0.7 m 0.8 m 0.9 m 1.0 m 1.5 m
Flange	-J -N -M -L -A -R -Q -T -S -E	----- ----- ----- ----- ----- ----- ----- ----- ----- -----	JIS 5K 50 FF JIS 10K 65 FF JIS 10K 80 FF JIS 10K 100 FF ANSI Class 150 4 RF ANSI Class 150 2 1/2 RF ANSI Class 150 3 RF JPI Class 150 3 RF JPI Class 150 4 RF DIN PN10 DN50 A
Style code	*B	-----	Style B
Option	Ejector Tag plate	/EJ1 /EJ2 /SCT	Ejector Assy with E7046EC Ejector Assy with E7046EN Stainless steel tag plate

Part No.	Description
K9292TP	SiC, insertion length 0.5 m
E7046CF	SiC, insertion length 0.6 m
K9292TQ	SiC, insertion length 0.7 m
E7046CG	SiC, insertion length 0.8 m
E7046CH	SiC, insertion length 0.9 m
E7046AL	SiC, insertion length 1.0 m
E7046BB	SiC, insertion length 1.5 m
K9292TV	SUS310S (JIS), insertion length 0.5 m
E7046CR	SUS310S (JIS), insertion length 0.6 m
K9292TW	SUS310S (JIS), insertion length 0.7 m
E7046CS	SUS310S (JIS), insertion length 0.8 m
E7046CT	SUS310S (JIS), insertion length 0.9 m
E7046AP	SUS310S (JIS), insertion length 1.0 m
E7046AQ	SUS310S (JIS), insertion length 1.5 m

Note: For high temperature probe adapter, be sure to specify the ZR22S probe length of 0.15 m.

## 5. Ejector Assembly for High Temperature Probe of Oxygen Analyzer

Part No.	Description
E7046EC	Needle valve; Rc1/4, Pressure gauge; R1/4, Ejector; Ø6 / Ø4 Tube joint
E7046EN	Needle valve; 1/4 NPT (F), Pressure gauge; 1/4 NPT (M), Ejector; 1/4 Tube joint

## 6. Probe Protector for Zirconia Oxygen Analyzer

Model	Suffix code	Option code	Description
ZO21R	-L	-----	Probe Protector (0 to 700°C)
Insertion length	-100	-----	1.05 m
	-150	-----	1.55 m
	-200	-----	2.05 m
Flange (*)	-J	-----	JIS 5K 65 FF
	-A	-----	ANSI Class 150 4 FF
Style code	*B	-----	Style B

\*: Thickness of flange depends on dimensions of flange.

## 7. Flow Setting Unit for manual calibration

Model	Suffix code	Option code	Description
ZA8F	-----	-----	Flow setting unit
Joint	-J -A	----- -----	Rc1/4 With 1/4 NPT (F) adapter
Style code	*C	-----	Style C

## 8. Stop Valve for Calibration gas line

Part No.	Description
L9852CB	Joint: Rc/4, Material: SUS316 (JIS)
G7016XH	Joint: 1/4 NPT (F), Material: SUS316 (JIS)

Part No.	Description
G7209XA	Nipple: R1/4, Material; SUS316 (JIS)
K9470ZN	Nipple: 1/4 NPT (F), Material; SUS316 (JIS)

## 9. Check Valve for Calibration gas line

Part No.	Description
K9292DN	Joint: Rc1/4, Material: SUS304 (JIS)
K9292DS	Joint: 1/4 NPT (F), Material: SUS304 (JIS)

## 10. Air Set

Part No.	Description
G7003XF	Joint: Rc1/4, Material: Zinc alloy
K9473XK	Joint: 1/4 NPT (F), Material: Zinc alloy with adapter
G7004XF	Joint: Rc1/4, Material: Zinc alloy
K9473XG	Joint: 1/4 NPT (F), Material: Zinc alloy with adapter

## 11. Pressure Regulator for Gas Cylinder

Part No.	Description
G7013XF	Inlet: W22 14 threads Outlet: Rc1/4
G7014XF	Inlet: W22 14 threads Outlet: 1/4 NPT (Female)

## 12. Heater Assembly

Style: S2

Model	Suffix code	Option code	Description
ZR22A	-----	-----	Heater Assembly for ZR22
Length (*1)	-015	-----	0.15 m
	-040	-----	0.4 m
	-070	-----	0.7 m
	-100	-----	1 m
	-150	-----	1.5 m
	-200	-----	2 m
Jig for change	-A	-----	with Jig (*2)
	-N	-----	None
—	-A	-----	Always -A

\*1 Suffix code of length should be selected as same as ZR22S installed.

\*2 Jig part no. is K9470BX to order as a parts after purchase.

(Note) The heater is made of ceramic, do not drop or subject it to pressure stress. Yokogawa shall not guarantee the heater assembly after its replacement.

Model	Suffix code	Option code	Description
ZR202A	-----	-----	Heater Assembly for ZR202
Length (*1)	-040	-----	0.4 m
	-070	-----	0.7 m
	-100	-----	1 m
	-150	-----	1.5 m
	-200	-----	2 m
	Jig for change	-A	-----
-N		-----	None
—	-A	-----	Always -A

\*1 Suffix code of length should be selected as same as ZR202S installed.

\*2 Jig part no. is K9470BX to order as a parts after purchase.

(Note) The heater is made of ceramic, do not drop or subject it to pressure stress. Yokogawa shall not guarantee the heater assembly after its replacement.

### 13. Calibration Gas Unit Case (E7044KF)

Case Paint: Baked melamine resin,

Jade green (Munsell 7.5 BG 4/1.5)

Installation: 2B pipe mounting

Weight: Approx. 10 kg

(Note) Export of such high pressure filled gas cylinders to most countries is prohibited or restricted.

## EXTERNAL DIMENSIONS

### 1. ZR22S Explosion-proof Zirconia Oxygen Analyzer, Detector

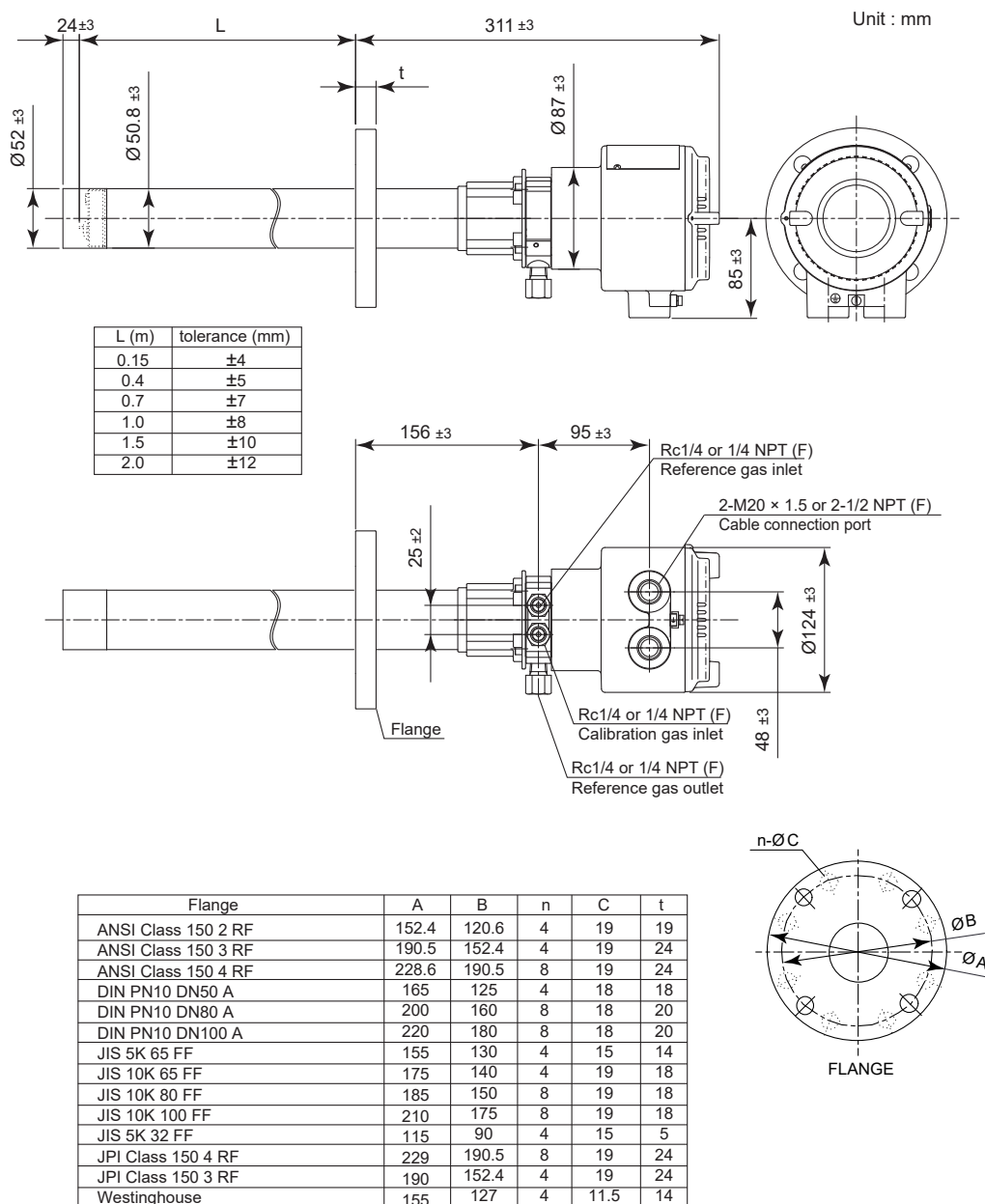

● Check Valve (option code /CV), Stop valve (option code /SV) -specified Calibration gas inlet

Unit: mm

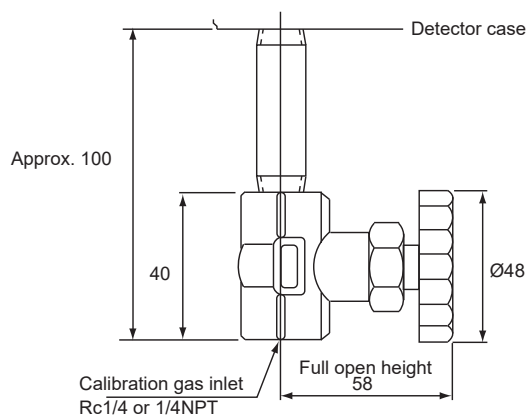

with Stop Valve (option: /SV)

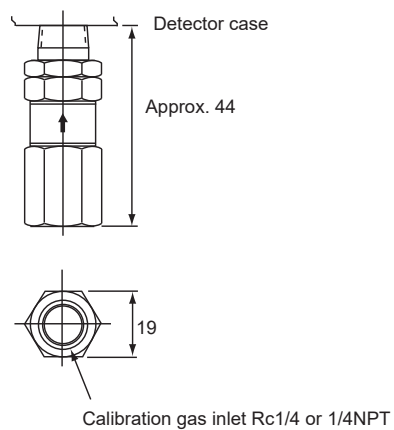

with Check Valve (option: /CV)

## 2. ZR802S Explosion-proof Zirconia Oxygen Analyzer, Converter

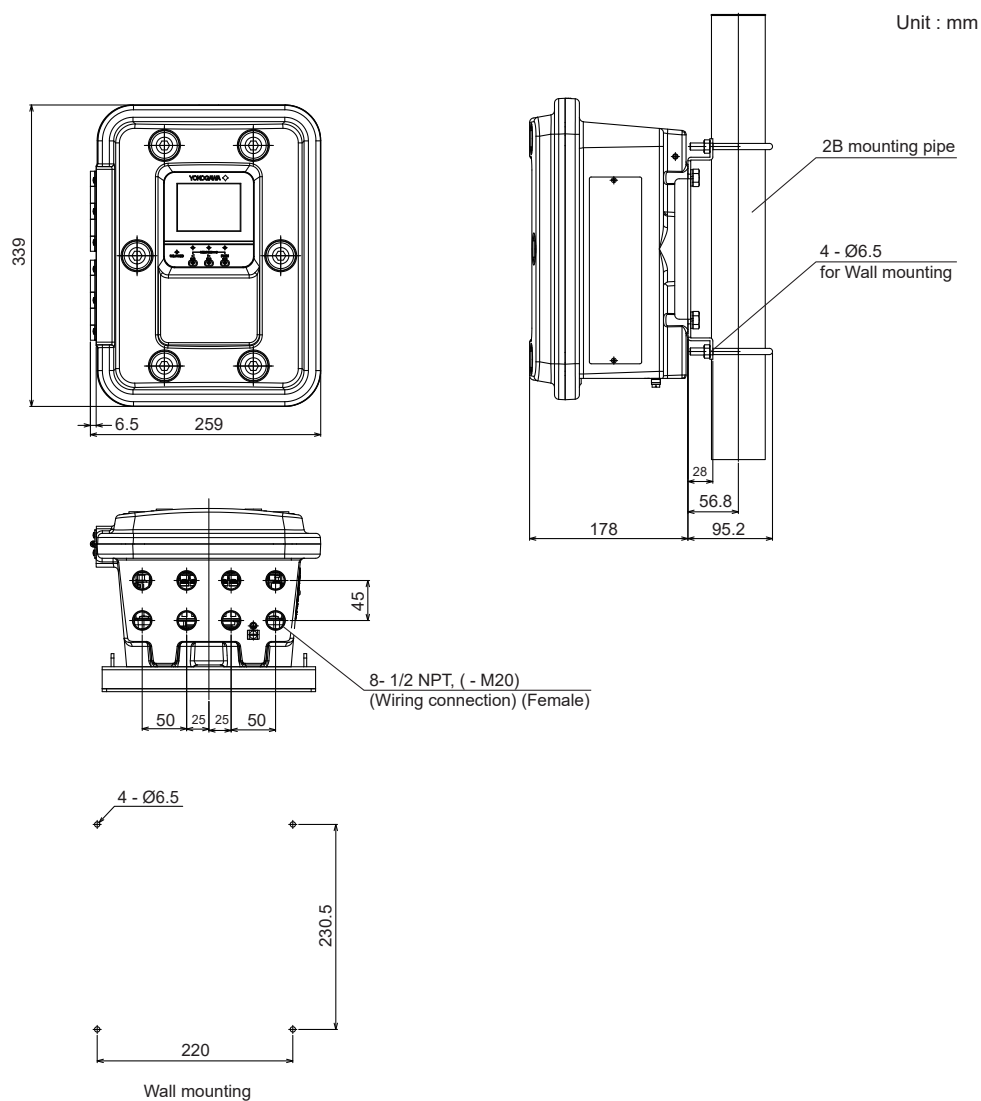

### ●With sun shield hood (option code /H)

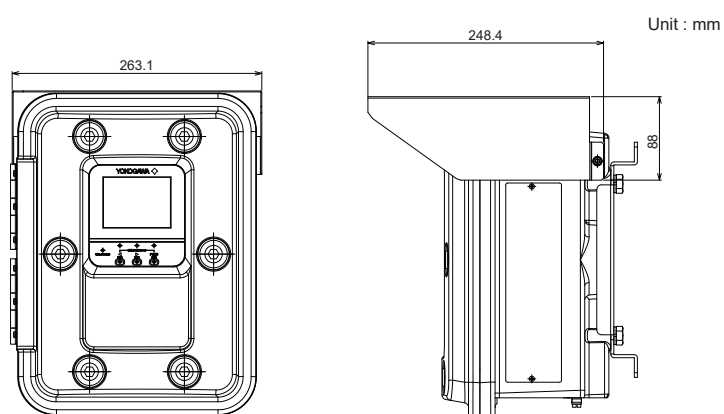

### 3. ZR202S Integrated type Explosion-proof Zirconia Oxygen Analyzer

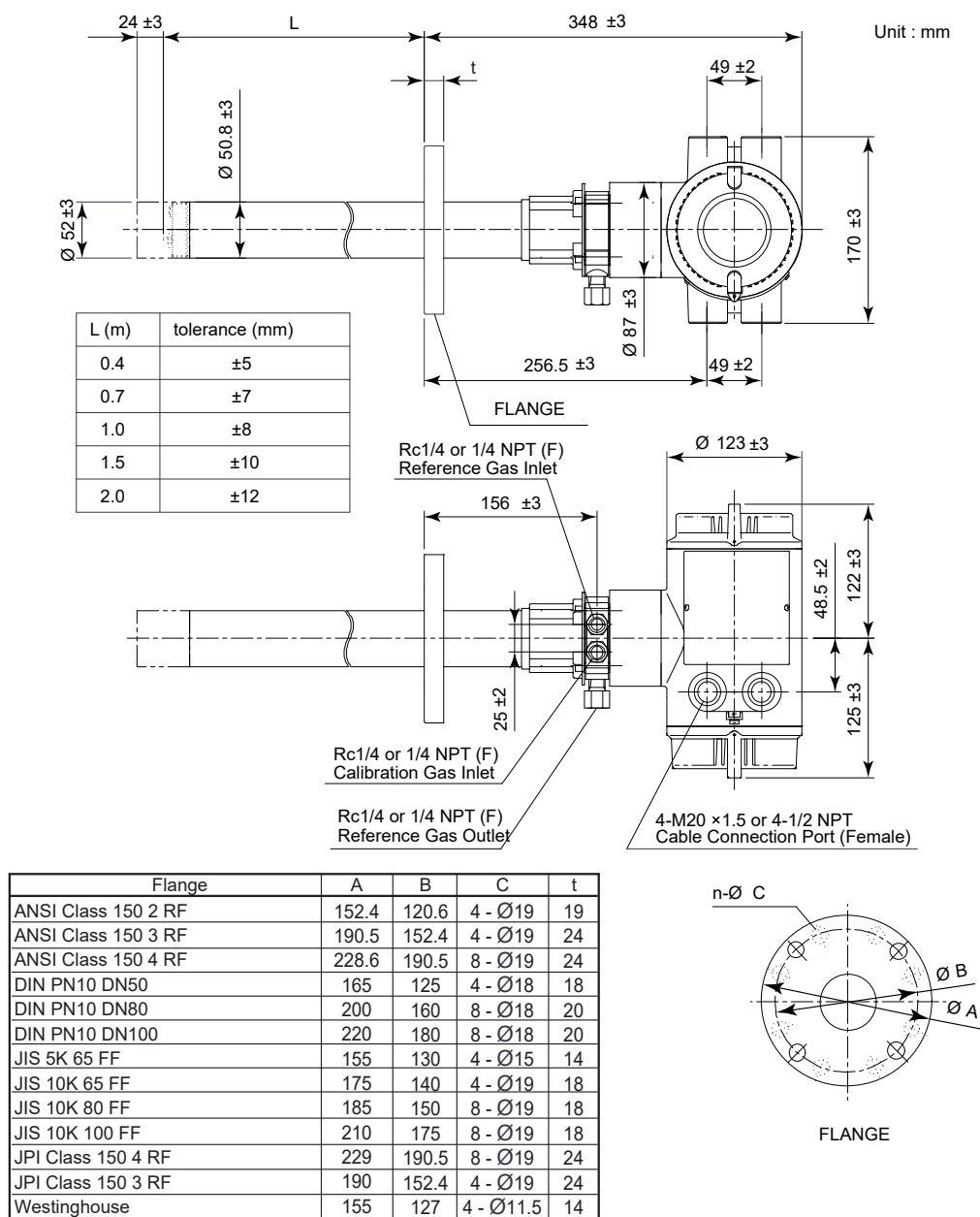

●With sun shield hood (option code /H)

Unit : mm

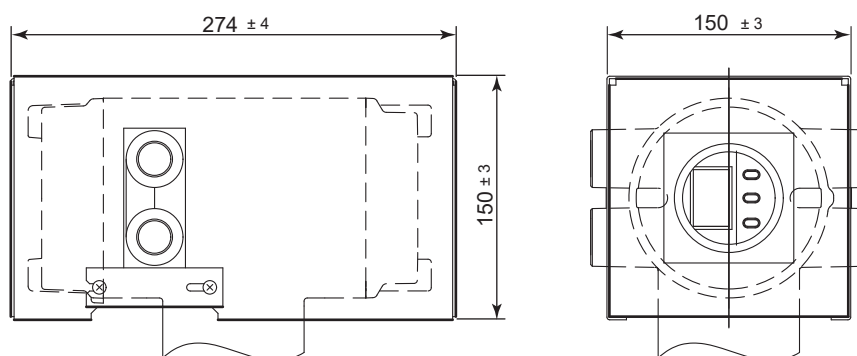

Material of HOOD : Aluminum

●Check Valve (option code /CV), Stop valve (option code /SV) -specified Calibration gas inlet

Unit: mm

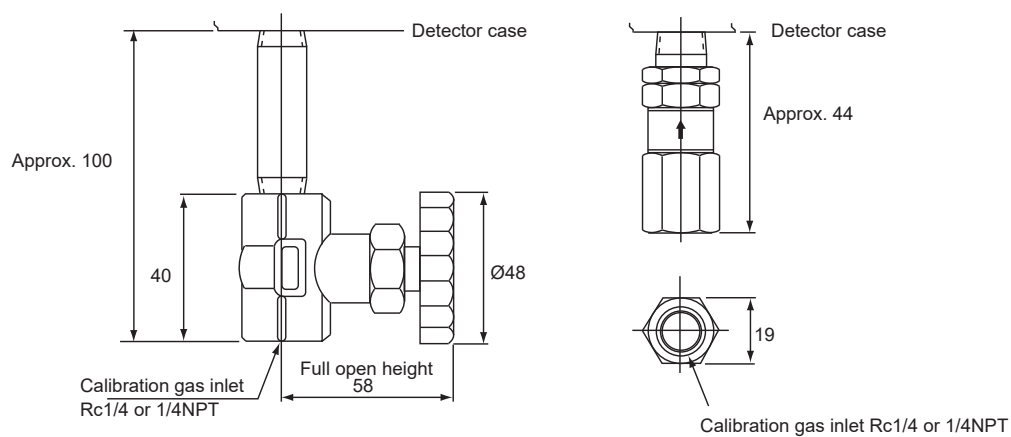

with Stop Valve (option: /SV)

with Check Valve (option: /CV)

## 4. ZO21P Probe Adapter for ZR22S

Unit: mm

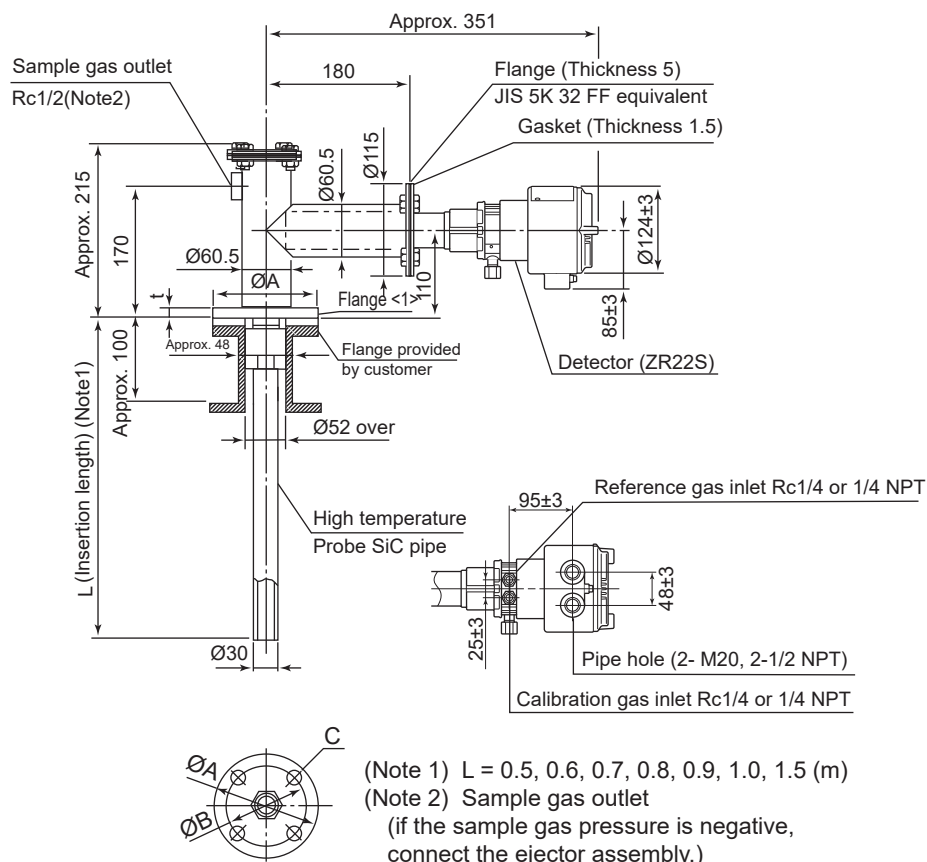

<1> Flange	A	B	C	t
JIS 5K 50 FF	130	105	4 - Ø15	14
JIS 10K 65 FF	175	140	4 - Ø19	18
JIS 10K 80 FF	185	150	8 - Ø19	18
JIS 10K 100 FF	210	175	8 - Ø19	18
ANSI Class 150 2 1/2 RF	177.8	139.7	4 - Ø19	22.4
ANSI Class 150 3 RF	190.5	152.4	4 - Ø19	24
ANSI Class 150 4 RF	228.5	190.5	8 - Ø19	24
JPI Class 150 3 RF	190	152.4	4 - Ø19	24
JPI Class 150 4 RF	229	190.5	8 - Ø19	24
DIN PN10 DN50 A	165	126	4 - Ø18	18

## 5. Ejector Assembly for High Temperature Probe of Oxygen Analyzer (E7046EC, E7046EN)

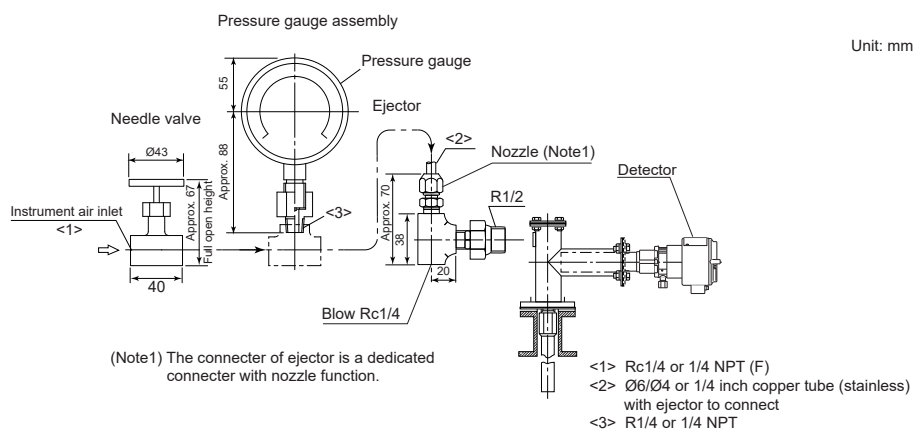

## 6. ZO21R Probe Protector for Zirconia Oxygen Analyzer

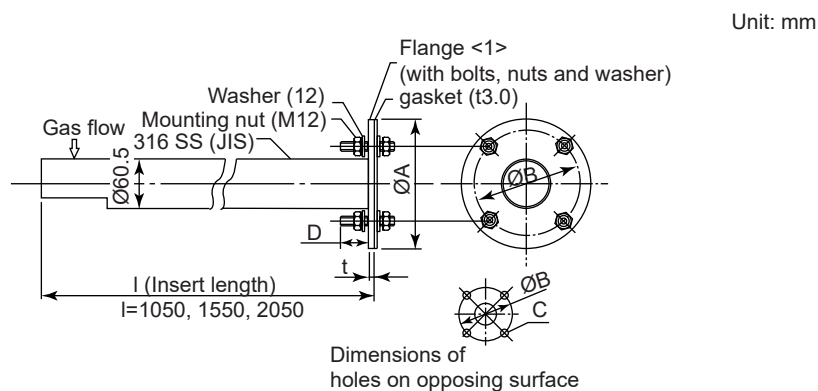

Flange<1>	A	B	C	t	D
JIS 5K 65 FF	155	130	4 - Ø15	5	40
ANSI Class 150 4 FF	228.6	190.5	8 - Ø19	12	50

7. ZA8F Flow setting unit for manual calibration

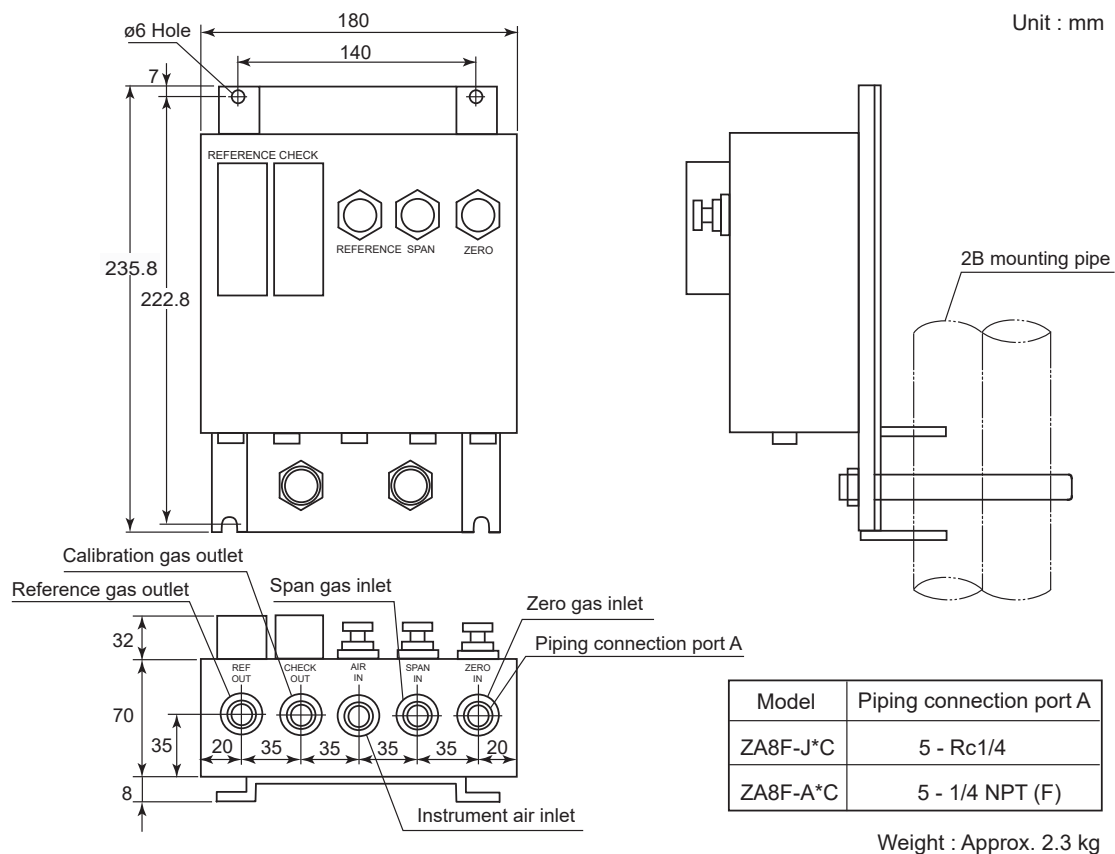

PIPING INSIDE THE FLOW SETTING UNIT

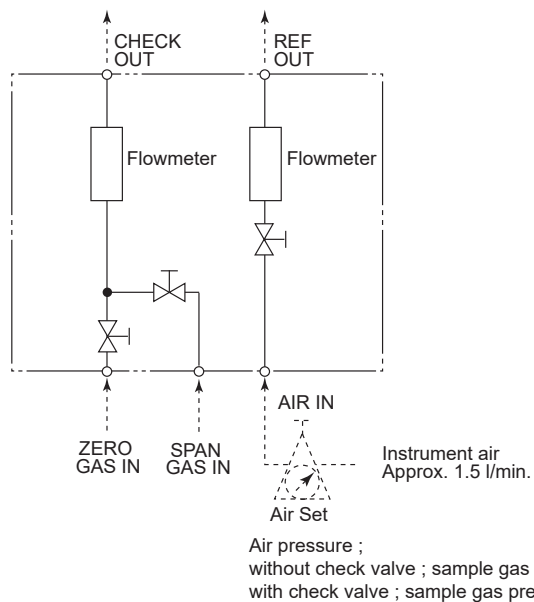

## 8. Stop Valve for Calibration gas line (L9852CB /G7016XH)

Unit : mm

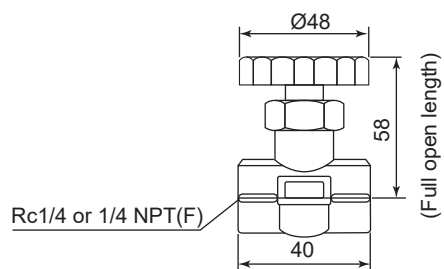

## 9. Check Valve for Calibration gas line (K9292DN /K9292DS)

K9292DN : Rc1/4(A), R1/4(B)

K9292DS : 1/4 NPT (Female) (A), 1/4 NPT(Male) (B)

Unit: mm

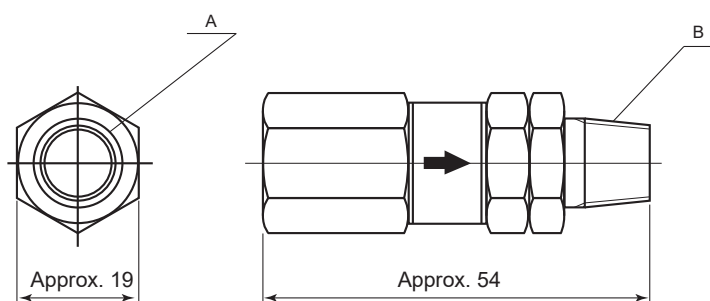

10. Air Set (G7003XF/K9473XK, G7004XF /K9473XG)

Unit : mm

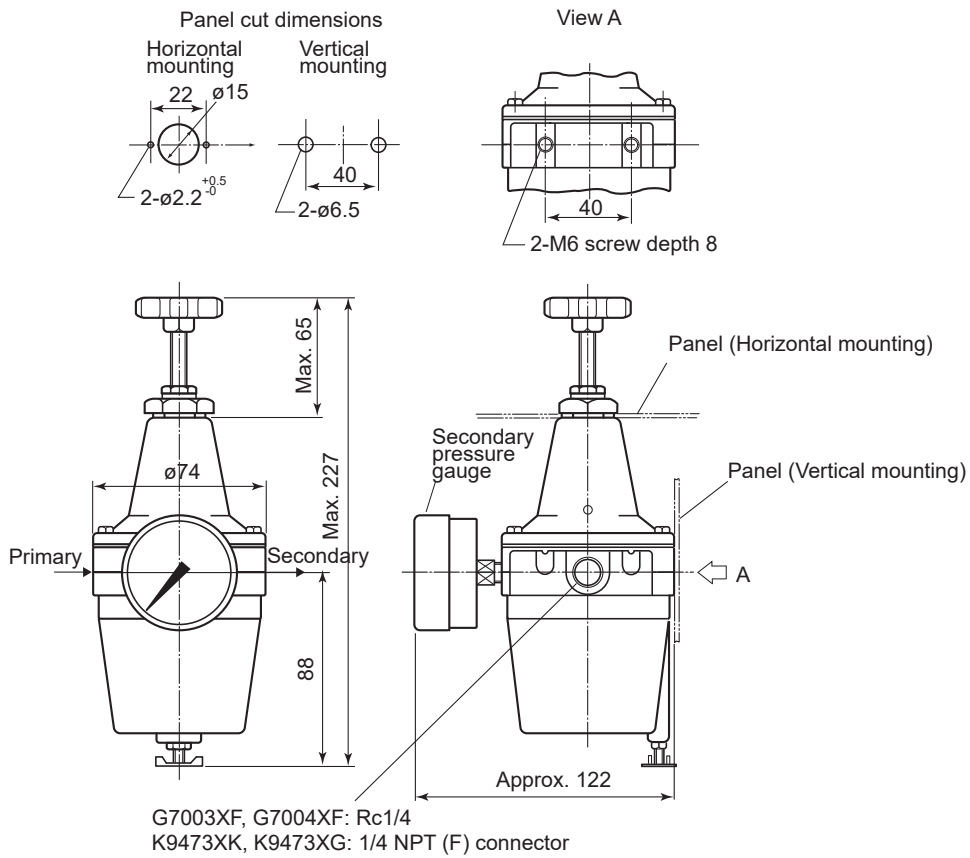

11. Pressure Regulator for Gas Cylinder (G7013XF/G7014XF)

Unit: mm

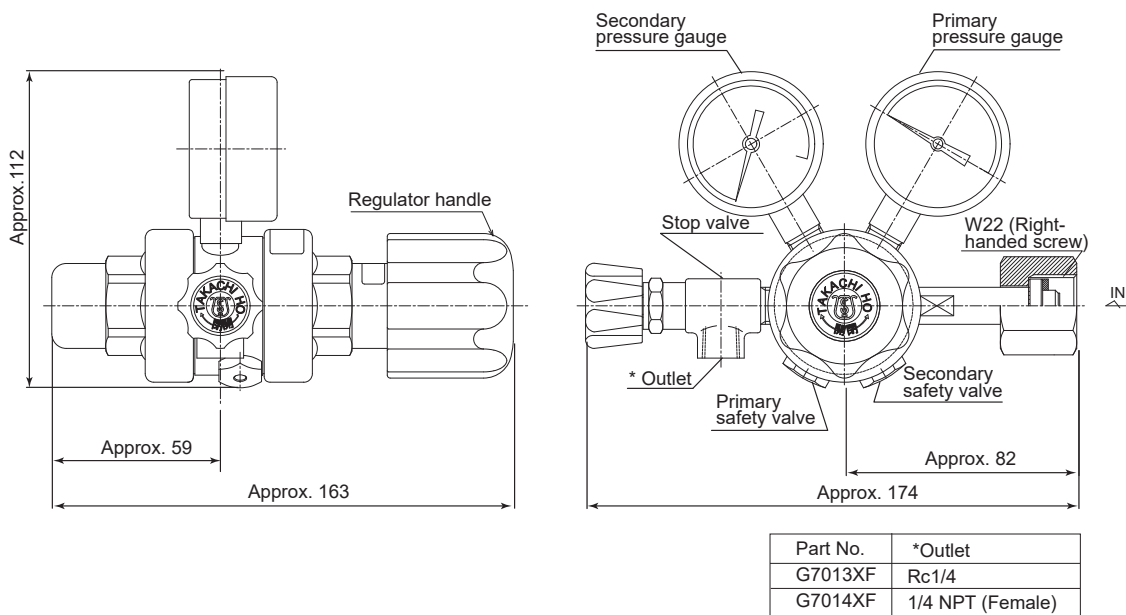

## 12. ZR22A, ZR202A Heater Assembly

### ● ZR22A Heater Assembly for ZR22S

Unit : mm

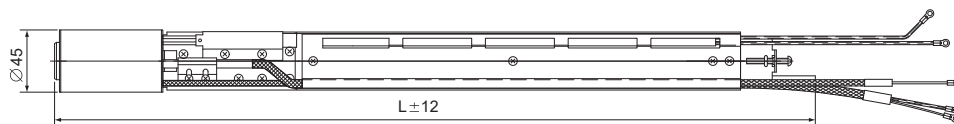

L: length

Model & Code	L	Weight (kg)
ZR22A-015	302	Approx. 0.5
ZR22A-040	552	Approx. 0.8
ZR22A-070	852	Approx. 1.2
ZR22A-100	1152	Approx. 1.6
ZR22A-150	1652	Approx. 2.2
ZR22A-200	2152	Approx. 2.8
ZR22A-250	2652	Approx. 3.4
ZR22A-300	3152	Approx. 4.0

□ ZR22A-□□□-A (Jig for change)

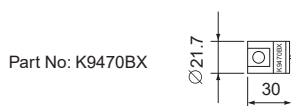

### ● ZR202A Heat Assembly for ZR202S

Unit : mm

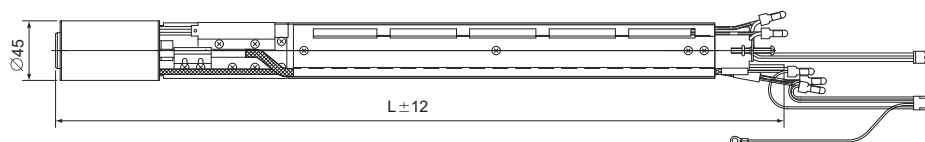

L: length

Model & Code	L	Weight (kg)
ZR202A-040	552	Approx. 0.8
ZR202A-070	852	Approx. 1.2
ZR202A-100	1152	Approx. 1.6
ZR202A-150	1652	Approx. 2.2
ZR202A-200	2152	Approx. 2.8
ZR202A-250	2652	Approx. 3.4
ZR202A-300	3152	Approx. 4.0

□ ZR202A-□□□-A (Jig for change)



### 13. Calibration Gas Unit Case (E7044KF)

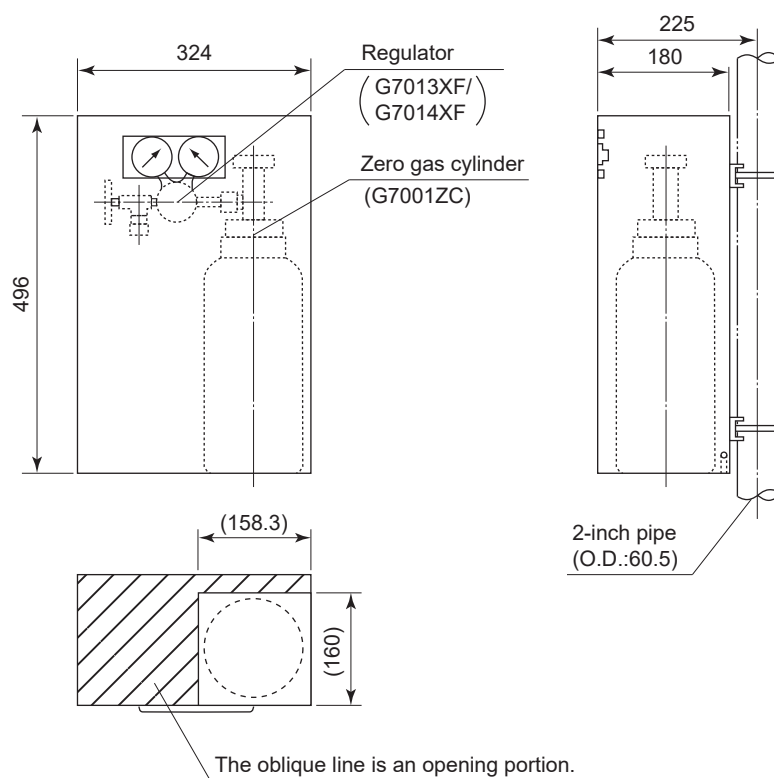

Note: The zero gas cylinder and the regulator valve are not included in the E7044KF

## ■ WIRING CONNECTIONS

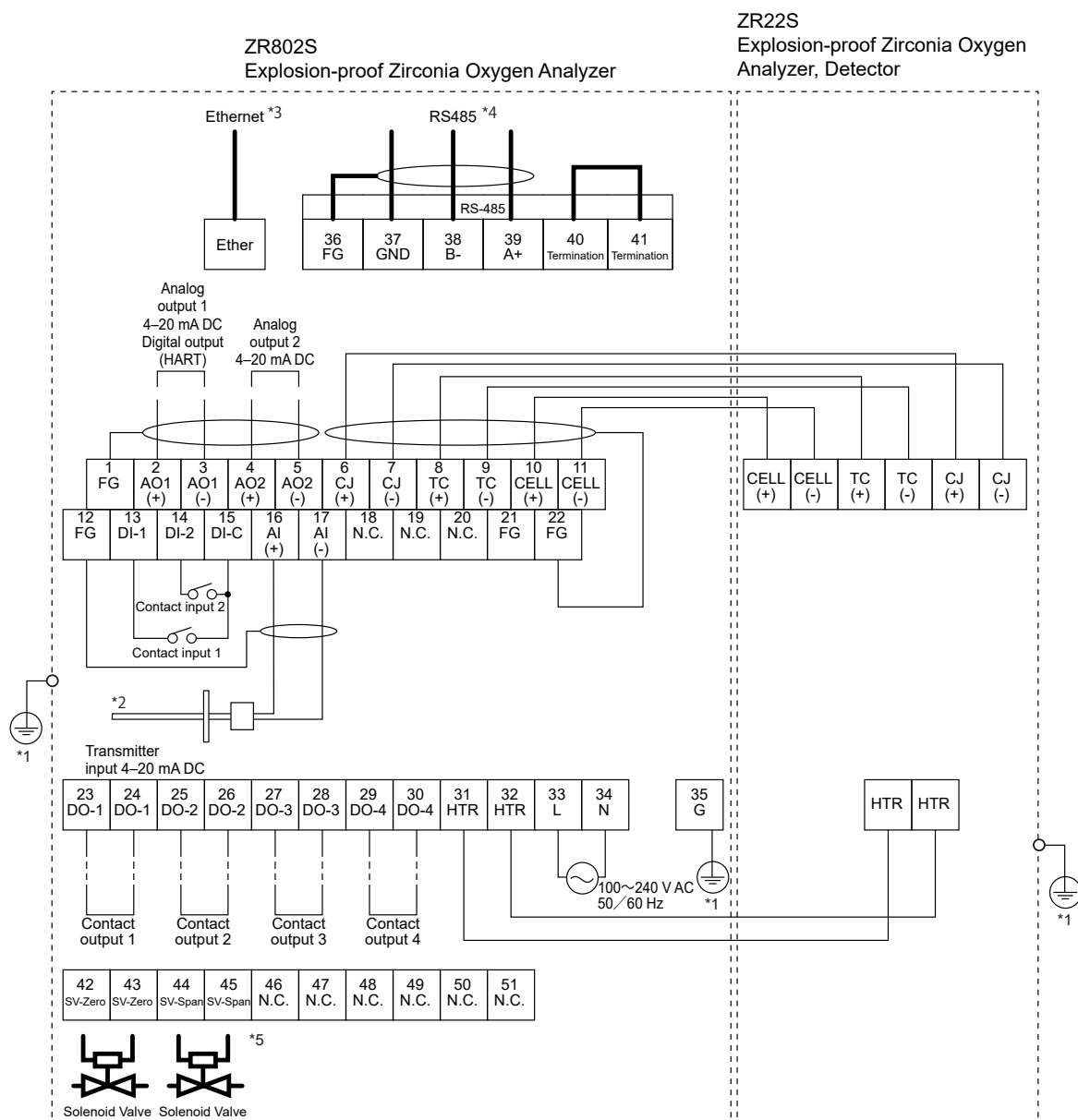

\*1: The ground wiring of the converter should be connected to either the protective ground terminal in the equipment or the ground terminal of the converter case.

Ground to earth, ground resistance: 100  $\Omega$  or less.

\*2: Option (Pressure transmitter provide by user).

\*3: Suffix Code "-E"

\*4: Suffix Code "-M"

\*5: With /AC Option

